

# DESIGNER LINE BASE MODEL

## Model: DRA43NSS

Natural Refrigerant R-290 Model

*Designer Line*

### 43" Base Worktop Refrigerator with Solid Doors



ENERGY STAR® Qualified Commercial Refrigerator

Heavy gauge #300 Series stainless steel top, stainless steel front, end panels and interior, galvanized steel rear and grill.



#### Options and Accessories

(upcharge and lead times may apply)

|                                  |   |
|----------------------------------|---|
| Stainless steel back             | Casters   |
| Overshelves (single or double)   | Door locks  |
| Add'l epoxy-coated steel shelves | Front breathing   |
| Stainless steel shelves          | Drawer in lieu of door section above the condensing unit* |
| Pan slides                       | Condensing unit left (standard on right)                  |

Consult factory for other model configurations, options and accessories.

\*Drawer section above condensing unit holds (1) 12 x 20 x 6 pan.

**Continental**  
Refrigerator

Toll-Free: 800-523-7138  
Phone: 215-244-1400  
Fax: 215-244-9579

539 Dunksferry Road  
Bensalem, PA 19020  
www.continentalrefrigerator.com

Project Name:

Model Specified:

Location:

Item No:

Quantity:

AIA #:

SIS #:

#### Standard Model Features

##### REFRIGERATION SYSTEM

Performance-rated refrigeration system

Natural, environmentally-safe, high-efficiency R-290 refrigerant<sup>1</sup>

Unique forced air design utilizes fans (approx. every 12") across the entire back of unit for even distribution of cold

Automatic, hot gas condensate evaporator

Non-corrosive, plasticized fin evaporator coil

Easily serviceable, back mounted compressor

Expansion valve system

##### CABINET ARCHITECTURE

2" non-CFC polyurethane foam insulation

Smooth, polished chrome door handles

Spring loaded, self closing doors

Magnetic snap-in door gaskets

Heavy-duty, epoxy-coated steel shelves

Completely enclosed, vented and removable rear and side grills

6" adjustable stainless steel legs

##### MODEL FEATURES

Electronic controller w/digital display & hi-low alarm

Electronic control, off-cycle defrost

Refrigerated section w/door above the condensing unit

Field rehingeable doors

<sup>1</sup> R-290 refrigerant meets all federal and state regulatory requirements.

*NOTE: Models come standard with a door over the condensing unit. A drawer over the condensing unit is an option.*

APPROVAL:

## Model Specifications

### DIMENSIONAL DATA

|   |                  |
|---|------------------|
| Net Capacity (cu. ft.)                            | 12 (340 cu l)    |
| Width, Overall (in.)                              | 43 (1092 mm)     |
| Depth, Overall (in.)<br>(incl. handles & bumpers) | 36 5/16 (922 mm) |
| Height, Overall (in.) (incl. 6" legs)             | 36 (914 mm)      |
| Shelf Area (sq. ft.)                              | 5.6 (.5 sq m)    |
| No. of Shelves                                    | 2                |
| No. of Full Doors                                 | 1                |
| No. of Half Doors                                 | 1                |
| Interior Depth (in.)                              | 30 (762 mm)      |
| Interior Height (in.)                             | 26 (660 mm)      |
| Interior Height (in.) (above condenser)           | 12 1/2 (318 mm)  |
| Interior Width (in.)                              | 39 (991 mm)      |

### REFRIGERANT DATA

|                             |      |
|-----------------------------|------|
| Condensing Unit Size (H.P.) | 1/4+ |
| Capacity (BTU/Hr)*          | 2610 |

### ELECTRICAL DATA

|                                     |                     |
|-------------------------------------|---------------------|
| Voltage (int'l)                     | 115/60/1 (220/50/1) |
| Total Amps (int'l)                  | 4.5 (2.1)           |
| 10 ft. Cord/Plug [attached] (int'l) | Yes (No)            |

### SHIPPING DATA

|                       |                  |
|-----------------------|------------------|
| Weight (lbs.)         | 345 (156 kg)     |
| Height - Crated (in.) | 43 3/4 (1111 mm) |
| Width - Crated (in.)  | 45 (1143 mm)     |
| Depth - Crated (in.)  | 47 (1194 mm)     |

\* Rating @ +25°F evaporator, 90°F ambient

Figures in parentheses reflect metric equivalents rounded to the nearest whole unit.



Equipped with one NEMA-5-15P Plug  
(varies by country)

# Continental<sup>®</sup>

Refrigerator

Toll-Free: 800-523-7138  
Phone: 215-244-1400  
Fax: 215-244-9579

539 Dunkserry Road  
Bensalem, PA 19020  
[www.continentalrefrigerator.com](http://www.continentalrefrigerator.com)

Due to our continued efforts in developing innovative products, specifications subject to change without notice.



MADE IN THE U.S.A.

© Copyright 2019, Continental Refrigerator.  
A Division of National Refrigeration & Air Conditioning Products, Inc.

## Model Plan Views

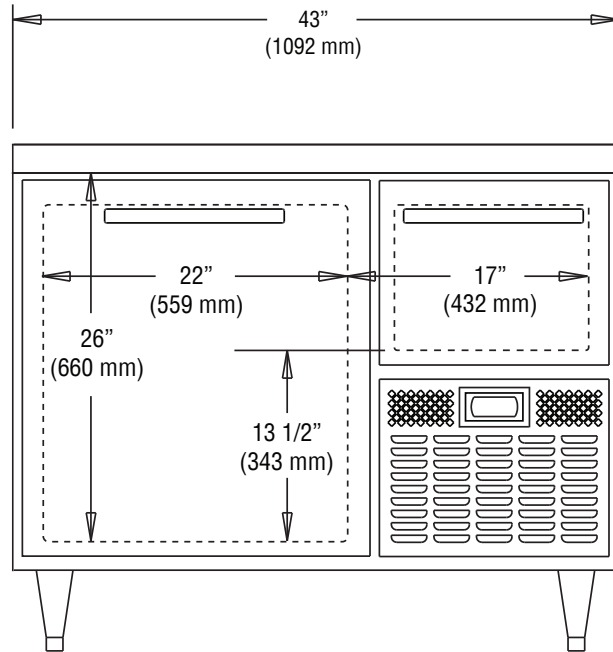

FRONT VIEW

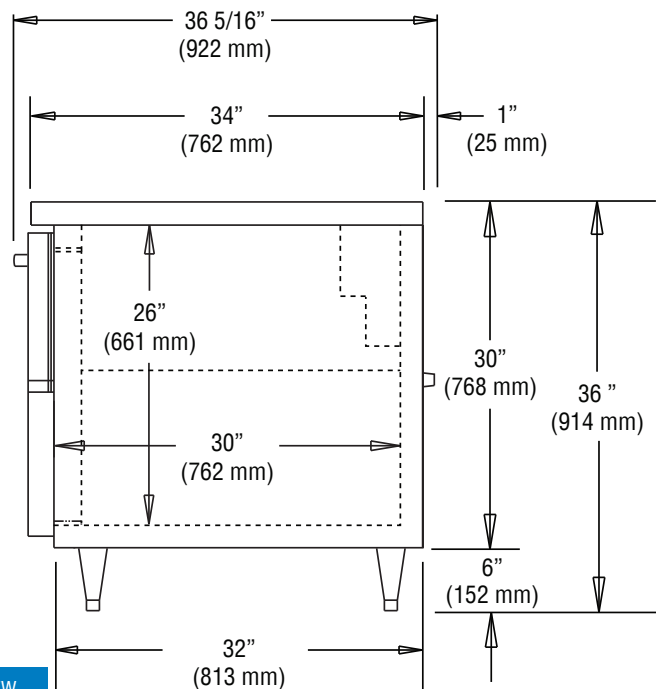

SIDE VIEW

**IMPORTANT NOTE:** If the cabinet is located directly against a wall, a minimum clearance of 3" is required on sides, front and rear.