

DESIGNER LINE BASE MODEL

Model: DRA60NSSBS

Natural Refrigerant R-290 Model

Designer Line

60" Base Worktop Refrigerator with Solid Doors and 5 1/2" Backsplash



ENERGY STAR® Qualified Commercial Refrigerator

Heavy gauge #300 Series stainless steel top, stainless steel front, end panels and interior, galvanized steel rear and grill.



Options and Accessories

(upcharge and lead times may apply)

Stainless steel back	Casters
Overshelves (single or double)	Door lock
Add'l epoxy-coated steel shelves	Front breathing
Stainless steel shelves	Drawer in lieu of door section above the condensing unit*
Pan slides (large door section only)	Condensing unit left (standard on right)

Consult factory for other model configurations, options and accessories.

*Drawer section above condensing unit holds (1) 12 x 20 x 6 pan.

Continental
Refrigerator

Toll-Free: 800-523-7138
Phone: 215-244-1400
Fax: 215-244-9579

539 Dunksferry Road
Bensalem, PA 19020
www.continentalrefrigerator.com

Project Name:

Model Specified:

Location:

Item No:

Quantity:

AIA #:

SIS #:

Standard Model Features

REFRIGERATION SYSTEM

Performance-rated refrigeration system

Natural, environmentally-safe, high-efficiency R-290 refrigerant¹

Unique forced air design utilizes fans (approx. every 12") across the entire back of unit for even distribution of cold

Automatic, hot gas condensate evaporator

Non-corrosive, plasticized fin evaporator coil

Easily serviceable, back mounted compressor

Expansion valve system

CABINET ARCHITECTURE

2" non-CFC polyurethane foam insulation

Smooth, polished chrome door handles

Spring loaded, self closing doors

Magnetic snap-in door gaskets

Heavy-duty, epoxy-coated steel shelves

Completely enclosed, vented and removable rear and side grills

6" adjustable stainless steel legs

MODEL FEATURES

Electronic controller w/digital display & hi-low alarm

Electronic control, off-cycle defrost

Refrigerated section w/door above the condensing unit

Field rehingeable doors

¹ R-290 refrigerant meets all federal and state regulatory requirements.

*NOTE: DRA60 models come standard with a door over the condensing unit, a smaller width door (left section) and larger width door (center section). A drawer over the condensing unit is an option. The option of having the door/drawers located in the opposite sections **MUST** be indicated at the time of ordering.*

APPROVAL:

Model Specifications

DIMENSIONAL DATA

Net Capacity (cu. ft.)	19 (538 cu l)
Width, Overall (in.)	60 (1524 mm)
Depth, Overall (in.) (incl. handles & bumpers)	36 5/16 (922 mm)
Height, Overall (in.) (incl. 6" legs)	41 1/2 (1054 mm)
Shelf Area (sq. ft.)	7.1 (.7 sq m)
No. of Shelves	4
No. of Full Doors	2
No. of Half Doors	1
Interior Depth (in.)	30 (762 mm)
Interior Height (in.)	26 (660 mm)
Interior Height (in.) (above condenser)	12 1/2 (318 mm)
Interior Width (in.)	56 (1422 mm)

REFRIGERANT DATA

Condensing Unit Size (H.P.)	1/4+
Capacity (BTU/Hr)*	3100

ELECTRICAL DATA

Voltage (int'l)	115/60/1 (220/50/1)
Total Amps (int'l)	4.5 (2.3)
10 ft. Cord/Plug [attached] (int'l)	Yes (No)

SHIPPING DATA

Weight (lbs.)	425 (193 kg)
Height - Crated (in.)	43 3/4 (1111 mm)
Width - Crated (in.)	62 (1575 mm)
Depth - Crated (in.)	47 (1194 mm)

* Rating @ +25°F evaporator, 90°F ambient

Figures in parentheses reflect metric equivalents rounded to the nearest whole unit.



Equipped with one NEMA-5-15P Plug
(varies by country)

Continental[®]

Refrigerator

Toll-Free: 800-523-7138
Phone: 215-244-1400
Fax: 215-244-9579

539 Dunkserry Road
Bensalem, PA 19020
www.continentalrefrigerator.com

Due to our continued efforts in developing innovative products, specifications subject to change without notice.



MADE IN THE U.S.A.

© Copyright 2019, Continental Refrigerator.
A Division of National Refrigeration & Air Conditioning Products, Inc.

Model Plan Views

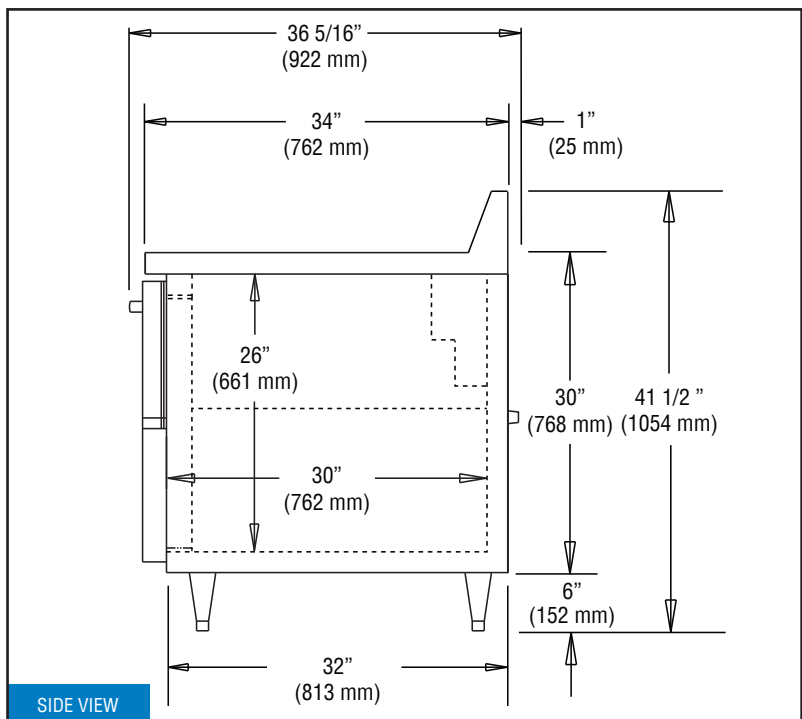
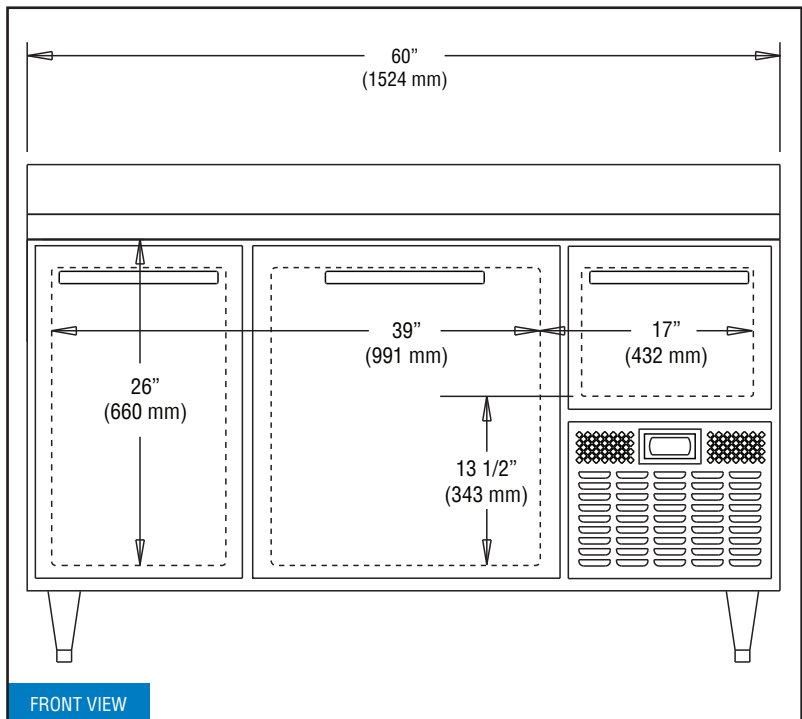

IMPORTANT NOTE: If the cabinet is located directly against a wall, a minimum clearance of 3" is required on sides, front and rear.