



Walk-In Installation Manual

**Norlake[®] Kold Locker[™], Fast-Trak[®], Fineline[™],
Enviro-Line & Mini Rooms**

Master-Bilt[®] Quick Ship, Bilt2Spec[™] & Ready-Bilt[™]



Table of Contents

Introduction	3
Product Safety Policy	4
Tools Required	5
General Information	6-10
Unpacking / Inspection	6
Foam Panel Storage	8
Construction Diagram	9
Section Latches	10
Walk-in Installation	11-34
Floor Installation	12
Site Selection, Base Preparation	14
Wall and Ceiling Panel Construction	22
Door / Door Section	25
Exterior Ramp	29
Interior Ramp	30
Membrane Roof	31
Electrical Connections	32
Wiring	32
Walk-in Maintenance	35-43
Door Parts	36
Electrical Connection	43
Final Checklist for Installation	44-45

Introduction

Your Refrigerated Solutions Group (RSG) Walk-In Cooler or Freezer was quality engineered and produced under rigid factory controls. It features the very latest in manufacturing technology plus innovative design techniques that will provide the ultimate in user convenience.

Please maintain this service-reference material in a handy file for an immediate answer to any questions you may have concerning your RSG Walk-In. This manual was designed not only to provide guidance during the installation phase, but to serve its owner as a reference source for years to come. It contains information pertaining to the operation of its various components, electrical wiring details, maintenance procedures and adjustment techniques or replacement methods for certain parts.

Please take time to read all sections of this manual. You will be rewarded with a better understanding of your equipment and will gain product knowledge that will assist you in obtaining the performance that you should expect from your RSG Walk-In.

Sincerely,

Refrigerated Solutions Group

Aaron Brown
President

ANY CORRESPONDENCE PERTAINING TO THIS EQUIPMENT MUST CONTAIN THE MODEL NUMBER AND THE SERIAL NUMBER AS THEY APPEAR ON THE DATA PLATE LOCATED ON THE INSIDE OF THE DOOR SECTION.

Refrigerated Solutions Group
891 County Road U
Hudson, WI 54016

800-955-5253 Norlake Foodservice Sales
800-477-5253 Norlake Scientific Sales
800-388-5253 Norlake Parts/Service

800-647-1284 Master-Bilt Sales
800-684-8988 Master-Bilt Parts/Service

PRODUCT SAFETY POLICY

We strive to provide those who buy product with equipment which is:

1. Developed by applying professional engineering principles in product research, development and user safety.
2. Designed to comply with or exceed industry performance and safety regulations.
3. Thoroughly reviewed and professionally tested for function, reliability and product safety.
4. Manufactured according to our professional purchasing, production and quality control standards designed to assure continued product reliability and safety.
5. Represented in our advertising and/or product literature in an informational and factual manner created to aid our customer in their product selection.
6. Accompanied by clear, complete installation, operation and maintenance instructions designed to assure many years of satisfactory product performance.
7. It is only through you, our satisfied customer, that we can continue our past successes in the design, development and manufacture of refrigeration equipment.
8. RSG reserves the right to improve upon our products without notice and without imposing on ourselves, any obligation to make such changes on products previously manufactured.

Warning: Walk-in floor must be kept free of any items that could cause a slip hazard. Spilled liquids, food particles or any moisture on the walk-in floor can cause the floor to become slippery. Keep the floor surface clean and dry at all times.

- Inspect non-skid floor strips on ramps and floor surfaces and replace if worn.
- Inspect refrigeration system, door gaskets and hardware for proper operation to prevent moisture on walk-in floor, ceiling or walls.
- Avoid leaving entry doors open for more than five minutes, which can cause a film of ice or moisture to form on floor, ceiling and wall surfaces due to the excessive condensation of warm moist air entering the walk-in. Vinyl strip curtains can be used to reduce the amount of warm moist air entering the walk-in.

TOOLS REQUIRED FOR UNCRATING AND INSTALLATION OF YOUR RSG WALK-IN



- LEVEL
- CAULK GUN
- TAPE MEASURE
- SAFETY GLASSES
- HAMMER
- METAL SNIPS
- PRY BAR
- PHILLIPS SCREWDRIVER
- ALLEN WRENCH
- UTILITY KNIFE
- SQUARE
- DRILL DRIVER

GENERAL INFORMATION

WALK-IN INSTALLATION GENERAL INFORMATION

This walk-in cooler or freezer was produced utilizing the latest in manufacturing technology, the highest quality materials available, along with innovations that make it a distinctive product in its field. Despite rigid controls in the production of the product, there is no substitute for thoroughly reading and UNDERSTANDING the instructions that follow. The result will be an orderly and efficient installation. Take the time to follow the steps explicitly! **NOTE: The most important step is to start with a level surface.**

NOTE: Indoor walk-in(s) must be in an environmentally controlled space. Relative humidity should be kept between 30% - 60%, maintaining a dew point of 50°F or less.



Delivery Receipt

UNPACKING / INSPECTION

Check the Delivery Receipt for the number of pieces that made up the shipment and make sure that the number of pallets, boxes or crates agrees with that number. Each piece should be clearly marked with the same order number that appears on the Delivery Receipt as the shipper's number. Each individual walk-in is color coded.

Examine the general condition of the shipment and, as soon as unpacking is completed, carefully inspect all parts for possible shipping damage. If damaged parts are discovered, contact RSG immediately.



Standard Walk-in panels



Refrigeration System with Control Panel

GENERAL INFORMATION

Remove protective packaging and locate the hardware bag.



The hardware bag contains accessory parts for this walk-in together with a construction diagram, a layout of the walk-in chamber including a screed assembly for floorless walk-ins, and a detailed packing list of all parts furnished for this individual walk-in. All parts should be compared to the packing list.

If discrepancies are found, contact RSG immediately. Some walk-ins come with an additional orange hardware box.



Locate packing list and use as a reference during uncrating.

Packing List			
Part Number		Description	Qty
1	101721-01	101-25X24X1 CORNER	1
2	101721-02	101-25 X 24 WALL	2
3	101721-03	101-25 X 24 WALL	2
4	101721-04	101-25 X 24 WALL W/ GFI OUTLET	1
5	101721-05	101-25 X 24 WALL W/ GFI OUTLET	1
6	101721-06	101-25 X 24 WALL W/ GFI OUTLET	1
7	101721-07	101-25 X 24 WALL W/ GFI OUTLET	1
8	101721-08	101-25 X 24 WALL W/ GFI OUTLET	1
9	101721-09	101-25 X 24 WALL W/ GFI OUTLET	1
10	101721-10	120 X 48 CEILING NT DRG	1
11	101721-11	120 X 48 CEILING MA DRG	1
12	101721-12	120 X 48 CEILING NT DR MAJ	1
13	101721-13	120 X 48 CEILING NT DR MAJ	1
14	101721-14	120 X 48 CEILING NT DR MAJ	1
15	101721-15	120 X 48 CEILING NT DR MAJ	1
16	101721-16	120 X 48 CEILING NT DR MAJ	1
17	101721-17	120 X 48 CEILING NT DR MAJ	1
18	101721-18	120 X 48 CEILING NT DR MAJ	1
19	101721-19	120 X 48 CEILING NT DR MAJ	1
20	101721-20	120 X 48 CEILING NT DR MAJ	1
21	101721-21	120 X 48 CEILING NT DR MAJ	1
22	101721-22	120 X 48 CEILING NT DR MAJ	1
23	101721-23	120 X 48 CEILING NT DR MAJ	1
24	101721-24	120 X 48 CEILING NT DR MAJ	1
25	101721-25	120 X 48 CEILING NT DR MAJ	1
26	101721-26	120 X 48 CEILING NT DR MAJ	1
27	157782	LED 11224PW LED OPTOELECTRONICS	1
28	149100	TRUSS CEILING ELEC ASSY OPTICAL	1
29	088072	CONDUIT ELEC 1/2\"/>	

GENERAL INFORMATION

FOAM PANEL STORAGE

If foam walk-in panels require storage at the job site prior to installation, the following steps must be taken to protect the panels against both staining from moisture and sunlight and denting by workers and traffic.

Whenever possible, the panels should be stored indoors, and should remain in the crating pallet they were originally shipped in. If the panels were uncrated as they were unloaded from the delivery truck, and they are being stored indoors, they should be stored vertically on skids with spacers between the panels.

When storing panels in a vertical position, always place the female rail (grooved) edge down (see illustration below.) This method of storing panels will provide proper ventilation, permit drain-off of condensation moisture and protect panels against the formation of white rust stains.

If the panels must be stored outdoors, follow the same procedure as indicated for indoor storage **WITH THIS ADDITION:** Cover the panels completely with an opaque polyethylene water-proof material to protect against rain, snow, heat and sunlight.

The illustration below shows the method for storage outdoors when panels are not left in palletized crates.

Note: RSG always recommends equipment to be installed once received but understands storage may be required. RSG does not guarantee issues related to storage, such as handling damage, storage damage, panel aging, etc. We would recommend the locks be oiled and the panels be wiped down with a white oil.

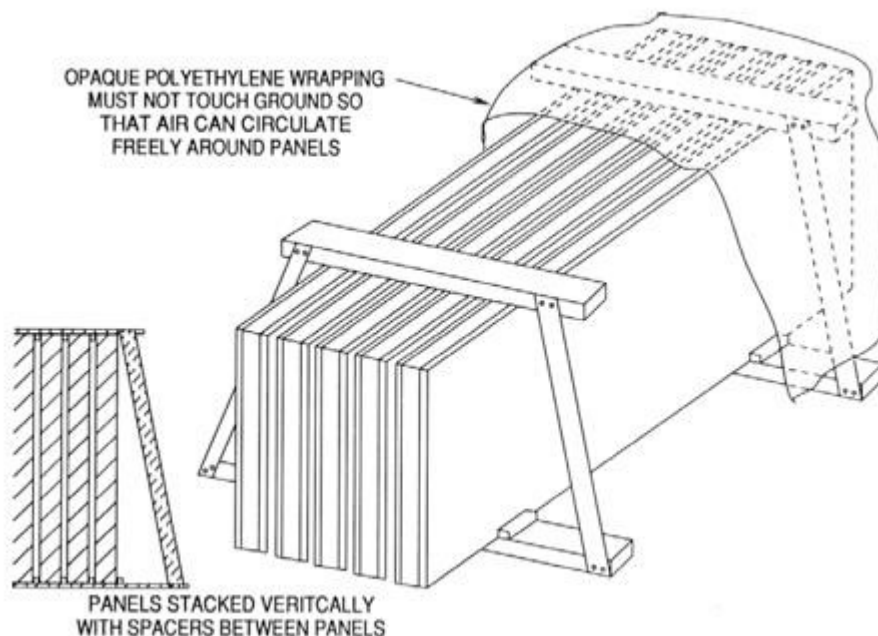

GENERAL INFORMATION

CONSTRUCTION DIAGRAM

The construction diagram, as furnished with each walk-in, is a detailed plan that illustrates the placement of every wall, corner, ceiling and floor panel that comprises a complete, individual walk-in.

The construction diagram for all installations clearly shows the direction of the male and female formed profile of every wall panel and every corner panel.

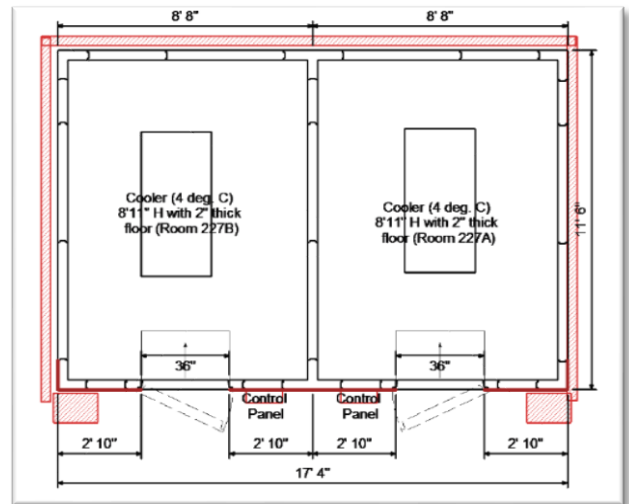

Construction Diagram

All sections used to construct your walk-in are marked with a specific part number on the section, corresponding with its location on the construction diagram.

If the walk-in is floorless, then a diagram showing the vinyl screed (floor sealer) arrangement is provided.

The vinyl screed combines the capability of retaining the wall panels in place while providing the inner and outer cove at the junction of the walls and the building floor (a requirement of Standard No. 7 of the National Sanitation Foundation (NSF).

IMPORTANT! Do not attempt to erect a floorless walk-in FREEZER on an existing building floor that has not been specially prepared and adequately insulated for below freezing storage temperatures!



RSG Inspection Label and Panel Specific Part Number

GENERAL INFORMATION

SECTION LATCHES

All wall, corner, ceiling and floor panels are joined and locked together by the mechanical action of section latches which are integrally foamed into the panels near the perimeter edges. A section latch consists of two halves – a lock housing which contains a cam actuated locking arm, or hook, and a strike housing which contains the engagement pin. Both housing halves are securely anchored in the foam core of the panel. The lock housing is always located in the male-formed edge and the strike housing will be found in the female-formed edge of the panel.



Fully Extended Cam Lock

TO OPERATE LATCHES



Hex wrench provided in hardware bag



1. Insert the hex wrench (packed in the hardware bag) through the access hole in the interior panel metal into the hex opening of the section latch. Turn wrench in a counterclockwise direction to ensure that the lock is fully unlatched



2. Push the sections tightly together and turn the wrench 1/4 turn in a clockwise direction. This will engage the locking arm (hook) over the pin in the strike housing.



3. Continue turning the wrench to a full stop (approximately 3/4 of a complete turn from the unlatched position) to complete the locking operation.



Latches on some panels will have to be turned counterclockwise to activate the locking cam. These latches will be designated by a "TURN" sticker.

WALK-IN INSTALLATION

SITE SELECTION, BASE PREPARATION AND LEVELING THE FLOOR WALK-IN COOLER OR FREEZER WITH A FLOOR

One of the most important considerations in the construction of a walk-in cooler or freezer is the building floor or the surface upon which the walk-in will rest. As with any structure, a firm and level foundation is essential to achieve a perfect result. If the surface is not perfectly level and smooth, appropriate steps must be taken to provide the proper base. The positive action of self-closing doors, proper door gasket seal and condensate removal all depend directly upon the level and plumb installation of all panels.

If the walk-in is to be installed next to an existing building wall(s), make sure that a MINIMUM OF 2" REMAINS BETWEEN THE WALK-IN AND THE BUILDING WALL(S) to allow for irregularities of the building wall(s) and to permit a free flow of air between the two surfaces.



NOTE: Indoor walk-in(s) must be in an environmentally controlled space. Relative humidity should be kept between 30% - 60%, maintaining a dew point of 50°F or less.

In some cases, the surface upon which the walk-in is to be installed was especially prepared for installation and it is perfectly level and smooth. The walk-in floor, in this case, may be installed without further preparation. Before beginning, however, an appropriate vapor barrier should be placed over the surface that the walk-in will occupy. Asphalt felt paper (50#) or a 6-mil polyethylene film, are suggested materials. **These are provided by the installing contractor.**

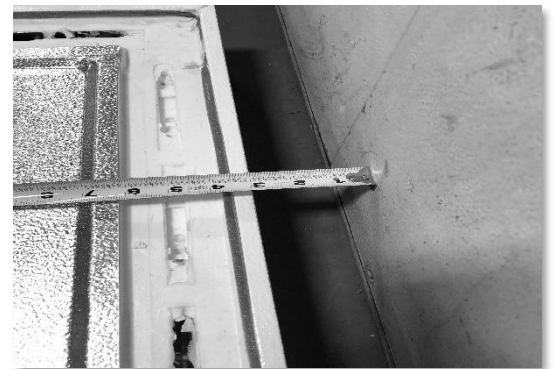

WALK-IN INSTALLATION

FLOOR INSTALLATION (Shim Leveling Method) FOR WALK-INS SUBJECT TO LIGHT TO MODERATE LOADS

Locate the highest point within the perimeter lines. A transit or surveyor's level or rotary laser level is an ideal instrument to use for locating this point. When the highest point is located, mark it directly on the floor and refer to the construction diagram to determine where the high point is located with respect to the walk-in floor plan.

One of the most important procedures that will be encountered in the construction of a walk-in with a floor is **LEVELING THE FLOOR**. It must be **PERFECTLY LEVEL!** If it is not, the wall panel will follow the irregularities of the walk-in floor which will directly affect subsequent procedures such as latching, panel gasket seal, ceiling panel assembly among others.

Using the construction diagram as a guide, select the floor panel that will be located directly over the highest point and place it in that position while observing the drawn outline on the building floor.

After the first floor panel is positioned, it must be properly leveled. To achieve this, shimming material of varying thicknesses must be used. Cedar building shingles are ideally suited for this procedure.

HOWEVER, OTHER MATERIALS THAT ARE RESISTANT TO ROTTING OR COMPRESSION ARE ALSO ACCEPTABLE.

IMPORTANT! EVERY FLOOR PANEL MUST BE SUPPORTED ON ALL FOUR SIDES AND THE ENTIRE

UNDERSIDE, AT LEAST EVERY 12" BY EITHER THE BUILDING FLOOR OR BY SHIMMING.

After the first floor panel has been leveled perfectly, trim away the excess shim material so that none projects from the panel at any of the four edges.

From the construction diagram, determine which floor panel will be installed next and where it will be situated on the floor plan. Prepare shimming material for the second panel at each point where shimming material was used beneath the first floor panel. The shimming material thickness must be such that it will support the second floor panel at the same height as the first panel along the entire length of the joint. NOTE: In many cases, the shimming material will be the same thickness as the adjacent shimming under the first panel.

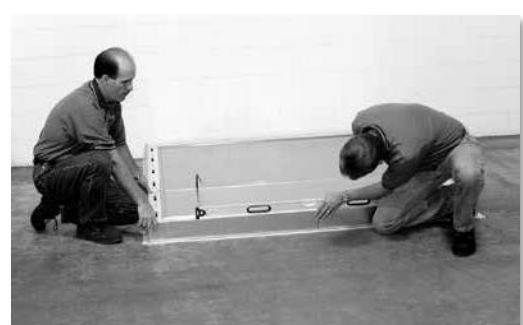

WALK-IN INSTALLATION

Place the second panel in position next to the first floor panel but **DO NOT LOCK!**



Shim the second panel, where necessary, using the same procedure as was used on the first panel. When all four edges of the second floor panel are properly shimmed, lock the two panels securely together. Using the same technique for leveling, check the levelness of the two sections in all directions by placing the level across the joint at several points and, again, check the levelness of the floor panels in the direction of the panel joint.



Refer to the construction diagram and install the remainder of the floor panels using the same procedure as was used for the first and second floor panels. When all the floor panels are installed and leveled perfectly, check the section latches for full and complete locking.



Trim excess vapor barrier.



WALK-IN INSTALLATION

SITE SELECTION, BASE PREPARATION

WALK-IN COOLER WITHOUT A FLOOR INSTALLED ON 1" VINYL SCREED

IMPORTANT! Do not attempt to construct a floorless walk-in FREEZER on an existing building floor that has not been specially prepared and adequately insulated for below freezing storage temperatures. **Note: All thermal breaks in floor slab must be exposed, including the partition wall.**

To install a vinyl screed assembly on an existing floor, proceed as follows:

Locate the screed (floor sealer) diagram, which was packed in the hardware box and, using it as a guide, draw an outline of the outside dimensions of the installed screed directly onto the building floor where the walk-in will be situated. These dimensions will be 1 1/2" larger than the overall dimensions of the walk-in in both directions.

If the walk-in is to be installed next to an existing building wall(s), make sure that a MINIMUM OF 2" REMAINS BETWEEN THE DRAWN OUTLINE AND THE BUILDING WALL(S) to allow for irregularities of the building wall (s) and to permit a free flow of air between the two surfaces. CAREFULLY CHECK FOR SQUARENESS by confirming that the two dimensions between opposite corners are equal (Figure 1).

One of the most important procedures that will be encountered in the base preparation is LEVELING THE SCREED. It must be PERFECTLY LEVEL! If it is not, the wall panels will follow the irregularities of the building floor which will directly affect subsequent procedures such as panel latching, panel gasket seal, ceiling panel assembly and others.

After the outline of the screed assembly is completed, locate the highest point within the outline on the floor where the screed will be installed. Screed sections are 5 1/2" wide. A transit or surveyor's level is an ideal instrument for this purpose. Mark the highest point on the floor (Figure 2) and, referring to the screed diagram, identify and locate the appropriate screed section and position it directly over the highest point.

Figure 1

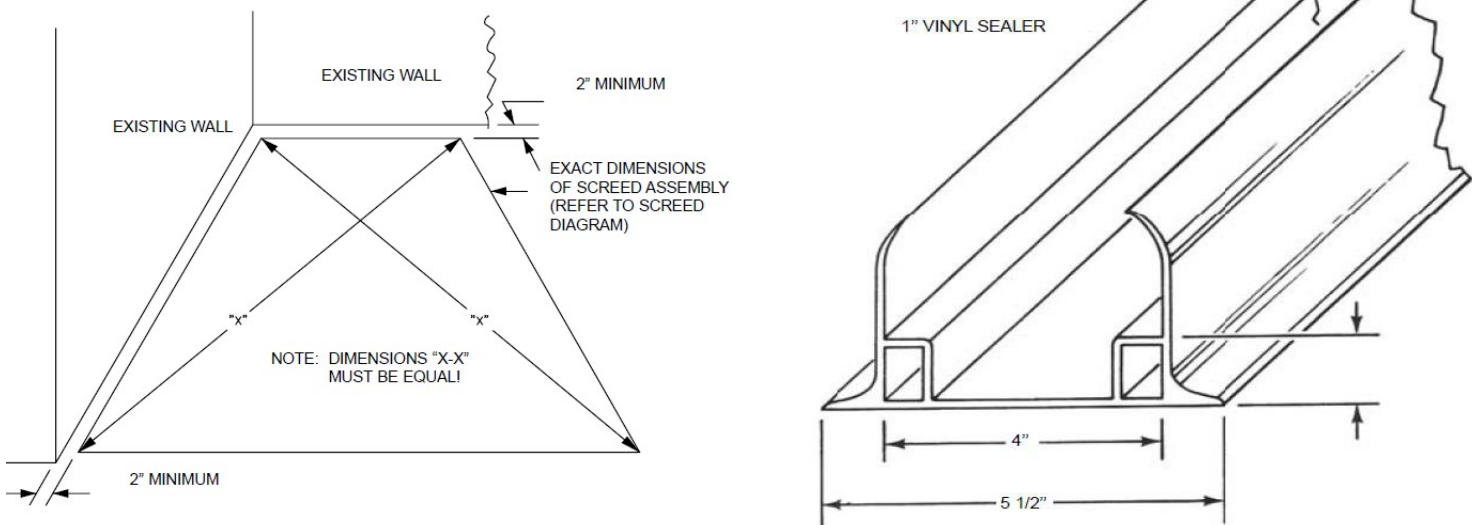

WALK-IN INSTALLATION

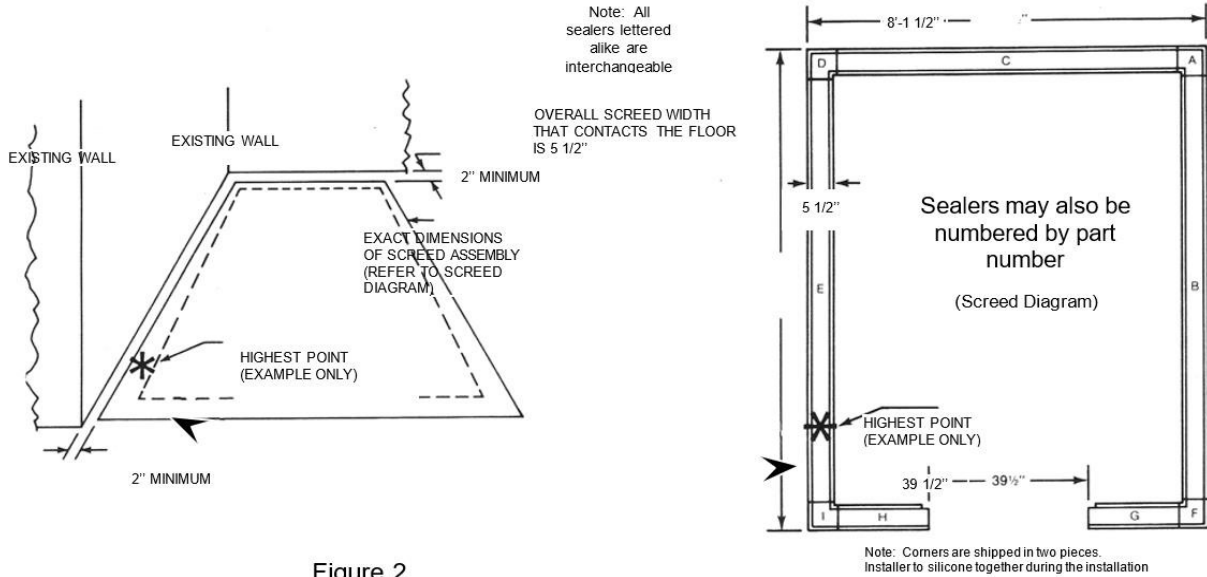

Figure 2

After the first screed section is positioned, it must be **LEVELED PERFECTLY** not only over its length but, across its width, as well. To achieve this, shimming material will most likely be required. Vinyl floor tile is ideally suited for this purpose. However, other materials that are resistant to rotting or compression are acceptable. **IMPORTANT!** EVERY SECTION OF SCREED MUST BE SUPPORTED AT LEAST EVERY 12" BY EITHER THE BUILDING FLOOR OR BY SHIMMING (Figure 3).

Assuming that the first screed section has been perfectly leveled, refer to the screed diagram and select an adjoining screed section and level it perfectly in both directions, shimming wherever necessary. Continue leveling the remainder of the screed sections until the entire assembly is in position. Check the assembly to make sure that the outer edges are located exactly on the drawn outline on the building floor.

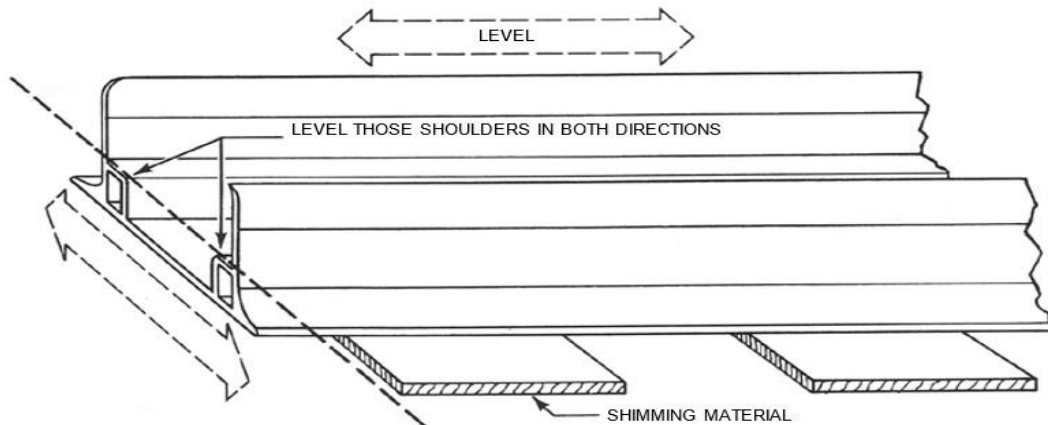

Figure 3

WALK-IN INSTALLATION

When the entire screed assembly is leveled and supported by shimming, as required, CAREFULLY AND WITHOUT DISTURBING THE SHIMMING MATERIAL, lift the screed sections, tip them upside-down and apply a heavy bead of construction sealant to the bottom of the screed section along both of the edges that contact the building floor surface. The diameter of the sealant bead should be larger than the thickest shimming material to ensure a complete, air-tight seal along the entire length of the screed (Figure 4). NSF approved sealant is provided and will be found in the hardware box.

Immediately after applying the construction sealant to a screed section, replace the screed section to its original location on the building floor WITHOUT DISTURBING THE SHIMMING MATERIAL and place a sealer splice every joint in the screed assembly (Figure 4). Since the sealer splice is intended to keep adjacent screed sections in alignment, approximately one-half of the sealer splice should lap each section. It need not be fastened in place (Figure 4). **NOTE: Seal all screed joints with sealant.** Make a final check for squareness, levelness and whether the screed assembly is located properly with respect to the drawn outline on the building floor.

Follow by securing the screed assembly to the building floor with fasteners that are appropriate for the building floor. These fasteners are not provided and must be obtained by others.

Fasteners should be applied down the center line of the inside of the screed at intervals of approximately 36"; however, where shimming is used, apply the fasteners through the shimming material, NOT BETWEEN the shimming. When the entire assembly is secured in position, trim away all excess construction sealant and shimming on both edges of the screed. Trim sealant flush with the edge of the screed and touch up any areas where the construction sealant is not making a perfect seal (Figure 4).

NOTE: If the building floor was specially prepared for the installation and no low or high points are detectable, it is possible that no shimming will be necessary. It will then only be necessary to apply construction sealant to the bottom of the screed and secure the screed directly to the building floor. The entire procedure, as described, must be followed explicitly, however, except for the details that pertain to the shimming.

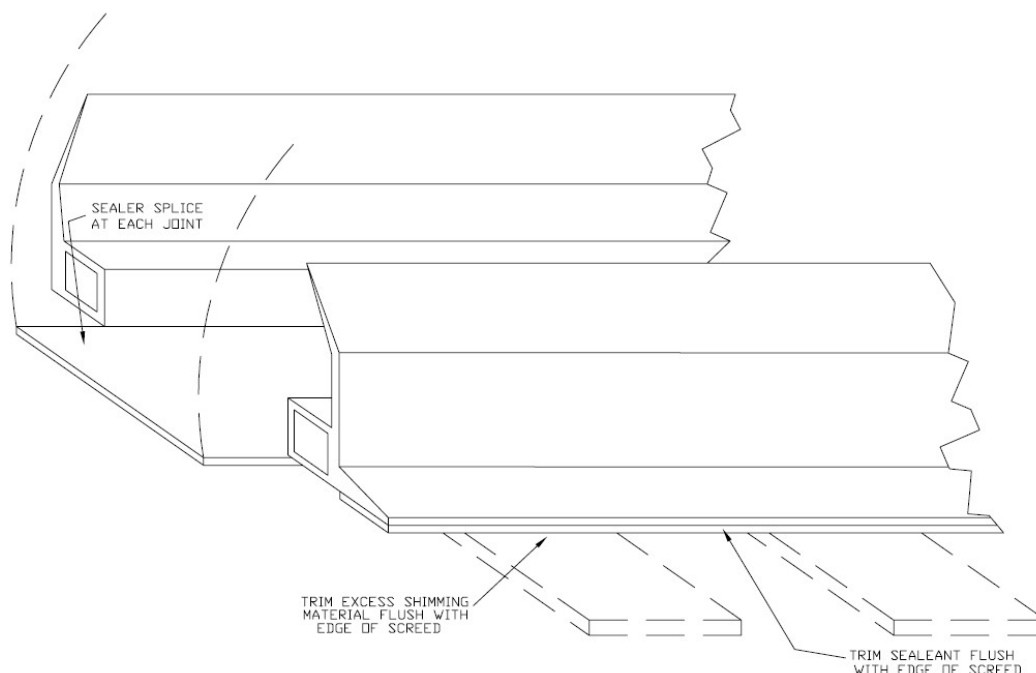

WALK-IN INSTALLATION

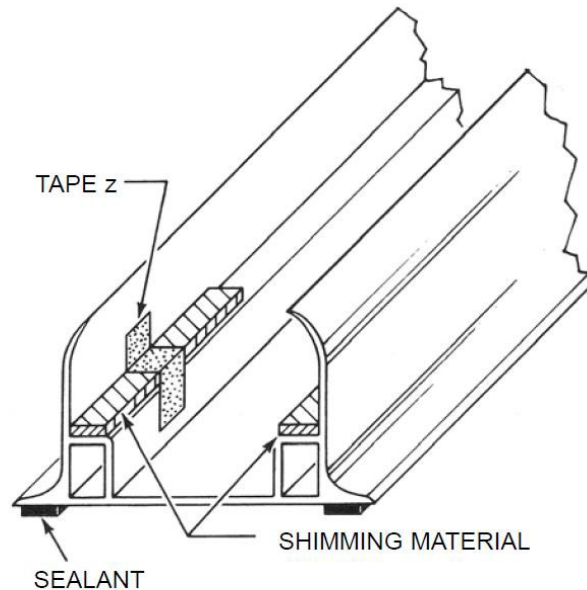

Figure 5

ALTERNATE SHIMMING METHOD FOR 1" VINYL SCREED

If the surface that the vinyl screed will occupy is level, except for an occasional low point, the screed may be secured directly to the building floor and compensation for the low points may be achieved by shimming the support shoulders on the inside of the screed.

When employing this method, the low points should be marked on the building floor in the vicinity of the drawn outline for reference. After the screed has been sealed and secured, leveling may proceed with special attention being focused in the areas marked as being low points.

Vinyl floor tile is often chosen as shimming material and strips (5/8" wide maximum) are cut and placed on top of the supporting shoulders of the screed to provide a level surface for the wall sections to rest upon. Strips of tape should be applied to hold the shimming material in place (Figure 5).

IMPORTANT! Shimming the support shoulders on the inside of the screed is ideally suited for minor irregularities on the building floor and has the advantage of complete screed-to-floor contact over the entire perimeter of the assembly. **IT IS NOT RECOMMENDED, HOWEVER, FOR EXTREMELY IRREGULAR BUILDING FLOORS.** Excessively thick shimming material on the support shoulders may elevate the wall panels to a point where the effectiveness of the uppermost screed sealing flanges would be compromised. Shimming thickness of more than 3/4" should be avoided! If shimming the support shoulders of the screed is selected, the entire procedure, as described, must be followed explicitly to ensure squareness and levelness over the entire screed assembly.

WALK-IN INSTALLATION

SITE SELECTION, BASE PREPARATION

WALK-IN COOLER OR FREEZER WITHOUT A FLOOR INSTALLED ON FOAMED SEALERS

IMPORTANT! Do not attempt to erect a floorless walk-in FREEZER on an existing building floor that has not been specially prepared and adequately insulated for below freezing storage temperatures. **Note: All thermal breaks in floor slab must be exposed, including the partition wall.** To install a foamed sealer (screed) assembly on an existing floor, or on a properly prepared floor for freezers, proceed as follows:

Locate the floor sealer (screed) diagram that was packed in the hardware box and, using it as a guide, draw a properly dimensioned outline of the sealer (screed) assembly directly onto the building floor precisely where the walk-in will be situated. These lines will be the same dimensions as the dimensions of the walk-in in both directions. If the walk-in is to be installed next to an existing building wall(s), make sure that a MINIMUM OF 2" REMAINS BETWEEN THE DRAWN OUTLINE AND THE BUILDING WALL(S). This space will allow for irregularities in the building wall(s) and will permit a free flow of air between the two surfaces. CAREFULLY CHECK FOR SQUARENESS by confirming that the dimensions between opposite corners are equal (Figure 1).

Since the foamed sealer (screed) is retained in position by a 3/8" thick plywood sealer guide, which will be secured to the building floor, it is imperative that the sealer guide be accurately located, as well, on the building floor. Refer to the sealer guide diagram which was also packed in the hardware box. On the diagram, you will notice that the sealer guide is located 7/8" INSIDE the drawn outline which represents the outside dimensions of the sealer (screed) assembly. Further, Fig. 1 illustrates that the sealer guide is 2 1/4" wide centered beneath a 4" wide sealer leaving a border of 7/8" along each edge. Draw another outline of the outside dimensions of the sealer guide directly onto the floor. There should be exactly 7/8" between the new sealer guide outline and the previously drawn sealer (screed) outline (Figure 2, on next page).

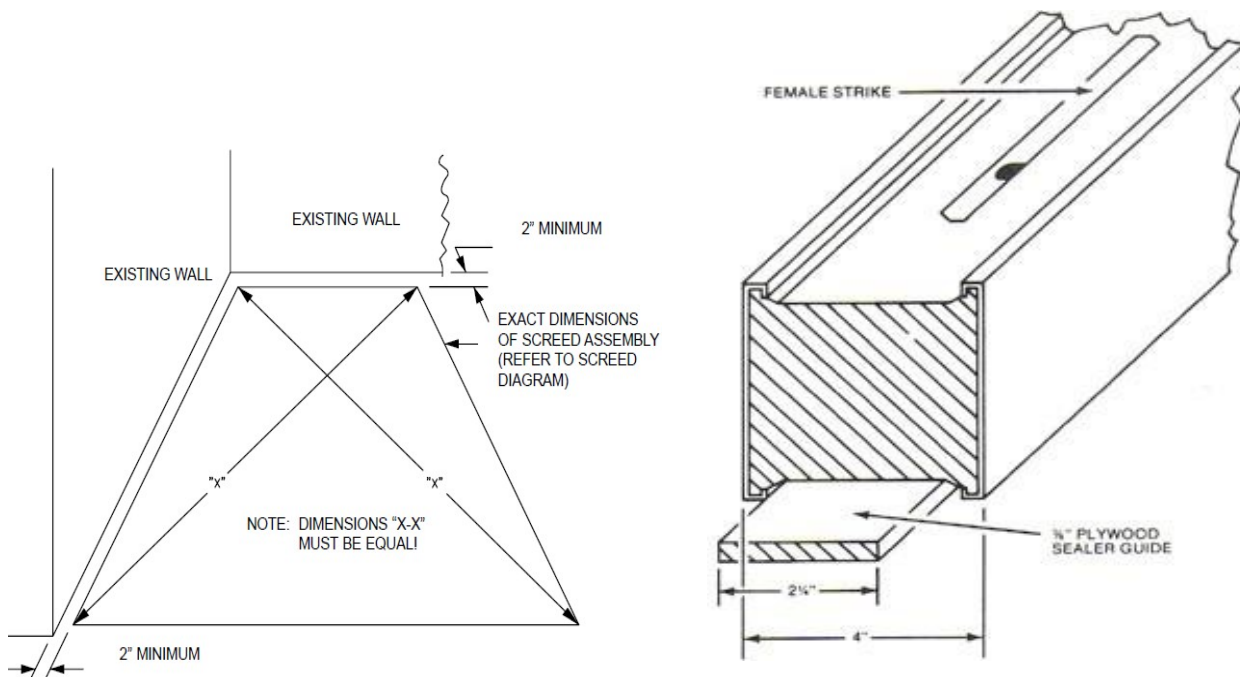

Figure 1

WALK-IN INSTALLATION

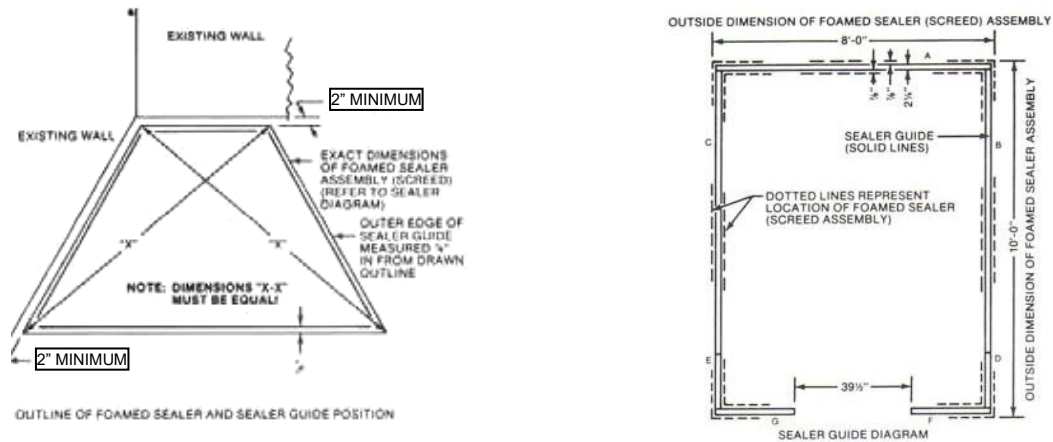

Figure 2

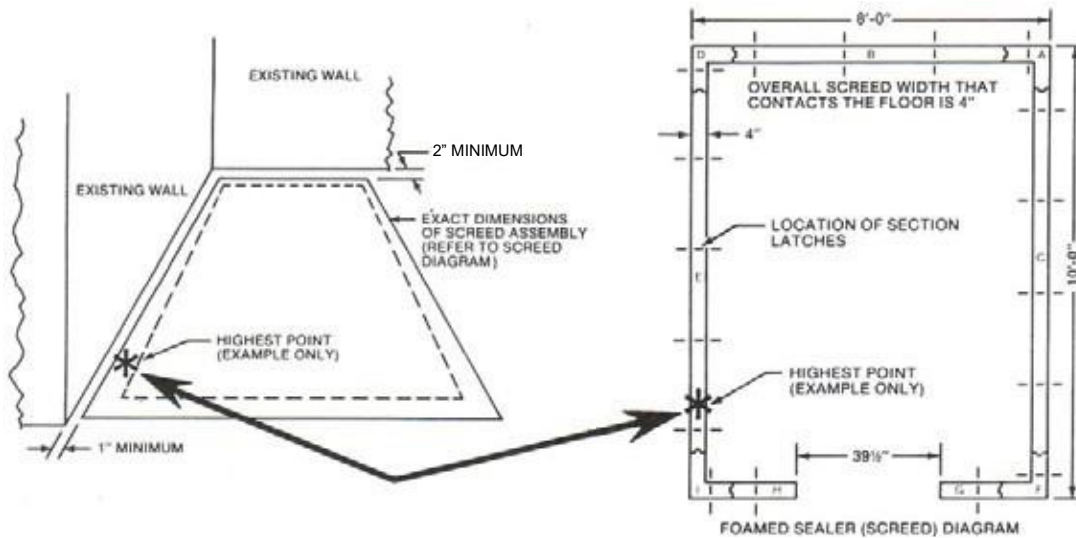

Figure 3

One of the most important procedures that will be encountered in the base preparation is **LEVELING THE SEALER (SCREED)**. It must be **PERFECTLY LEVEL!** If it is not, the wall panels will follow the irregularities of the building floor which will directly affect subsequent procedures such as panel latching, panel gasket seal, ceiling panel assembly and other.

After the outline of the sealer (screed) and the sealer guide is completed, as shown in Figure 2, locate the highest point within the outline on the floor where the screed (sealer) will be installed. (Sealer sections are 4" wide). A transit or surveyor's level is an ideal instrument for this purpose. Mark the highest point on the floor as illustrated on Figure 3.

WALK-IN INSTALLATION

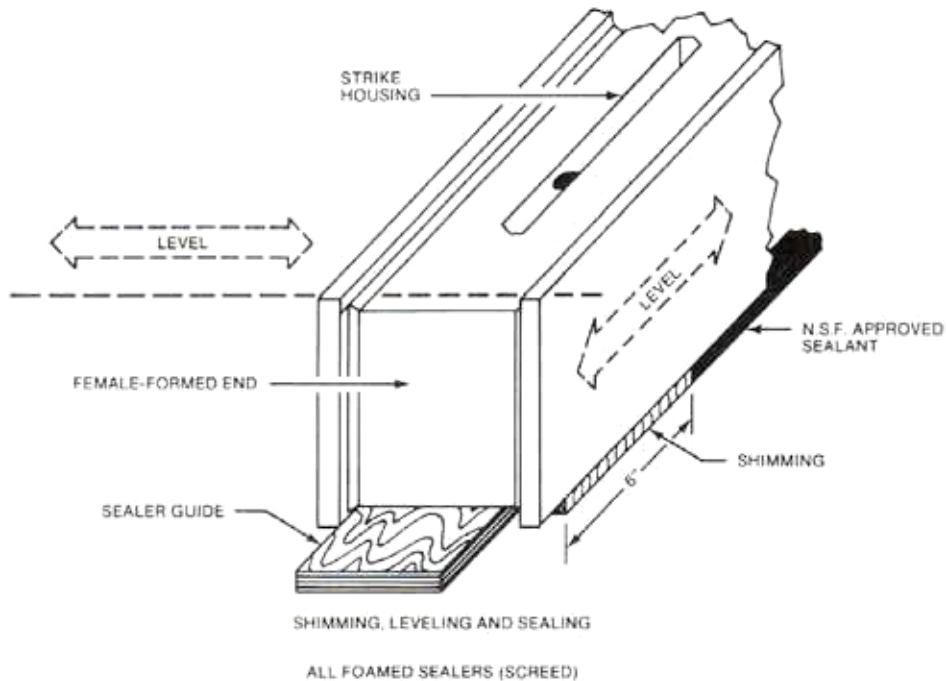

Figure 4

SEALER GUIDE INSTALLATION

Locate the SEALER GUIDES. They are bundled together and packed along with the walk-in corner or wall panels and are labeled accordingly. Sealer guides are strips of 3/8" plywood 2 1/4" wide as shown in Figure 1.

Refer to the SEALER GUIDE DIAGRAM. Select the proper sealer guides and position them as shown by the circled letters on the diagram.

Each sealer guide, when positioned properly, will have its outer edge precisely over the INSIDE OUTLINE drawn on the building floor, Figure 2, and its outer edge will be exactly 7/8" from the outline which represents the foamed sealer outer edge. The quality of workmanship performed in locating and securing the sealer guides will be transmitted directly to the location of the foamed sealers (screeds) and, subsequently, to the overall construction of the complete walk-in. BE EXACT! Refer to Figure 1 and Figure 2.

When all sealer guides are in position, make a final CHECK FOR SQUARENESS and secure them to the building floor with fasteners that are appropriate for the surface. **NOTE:** This can either be a mechanical fastener or construction grade adhesive. If the sealer guide is positioned over a polystyrene or polyurethane thermal breaker, a compatible construction adhesive may be used.

FOAMED SEALER (Screed) INSTALLATION

Refer to the FOAMED SEALER DIAGRAM. Identify and locate the sealer section that will be positioned directly over the highest point which was determined earlier and marked on the building floor (Figure 3).

NOTE: All foamed sealers are male formed on one end and female formed on the opposite end. The configuration of the ends is clearly indicated on the diagram. Also, make certain that the strike housing portion of the section latches is visible on the upper edge of the sealer when it is in position (see Figure 1 and Figure 2).

WALK-IN INSTALLATION

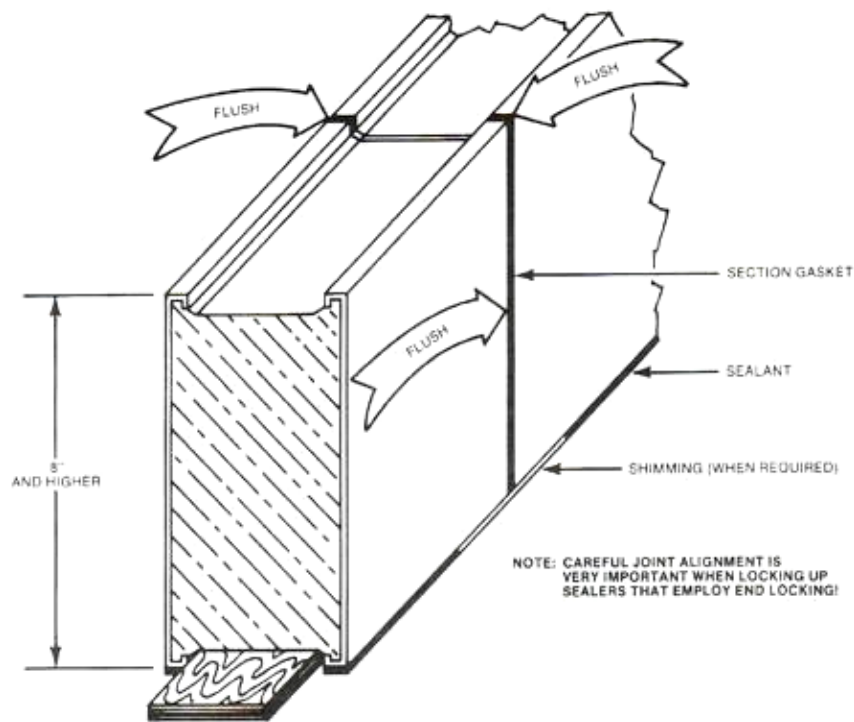

Figure 5

After the first sealer (screed) section is positioned over the sealer guide and over the highest point, it must be **LEVELED PERFECTLY** not only over its length but, across its width, as well. To achieve this, shimming material will probably be required. Vinyl floor tile cut in strips 7/8" wide by 6" long make ideal shimming strips that can be placed beneath the sealer, wherever necessary, to achieve levelness.

IMPORTANT: EVERY SECTION OF SEALER (SCREED) MUST BE SUPPORTED AT LEAST EVERY 24" BY EITHER THE BUILDING FLOOR OR BY SHIMMING. Avoid using shimming strips less than 6" long whenever possible (see Figure 4).

Assuming that the first sealer (screed) section has been perfectly leveled, refer to the sealer diagram and select an adjoining sealer section and level it perfectly in both directions, shimming wherever necessary. NOTE: Sealer (screed) sections 8" high or more employ section latches for end-to-end locking. **CAREFULLY** flush the upper edges and the inner or outer surfaces of adjoining sealer sections while locking them together (Figure 5). Continue leveling the remainder of the sealer sections until the entire assembly is in position.

When the entire sealer assembly is leveled, apply NSF approved sealant to achieve a vapor seal between the bottom edge of the sealer and the building floor. This sealant is provided and is packed in the hardware box. The sealant must be applied to the inner and outer surfaces of the sealer (screed) assembly. Make certain that the sealant produces a complete, air-tight seal, without gaps, and that special care is taken to seal the shimming material appropriately.

After the sealant has had an opportunity to set up, trim away all excess material flush with the edges of the sealer (screed) assembly and touch up any areas where the sealant is not making a perfect seal (Figure 5.).

WALK-IN INSTALLATION

WALK-IN INSTALLATION WALL AND CEILING PANEL CONSTRUCTION

The installation instructions that follow apply to any walk-in cooler or freezer where the wall panels are supported either by foamed walk-in floor panels or by a floor sealer (screed) assembly which has been accurately located and properly leveled. **NOTE:** The procedure for constructing wall and ceiling panels will be identical in all cases. **NOTE:** The walls do not lock to vinyl sealers but will lock to foam sealers when used.

To aid in the construction process, the floor plan furnished with your walk-in has part numbers listed for each wall, corner, ceiling and floor section. Match the part number on the floor plan to the label on the interior of each panel to determine the current placement for each panel.

Notice, also, that the section latch access holes on the vertical edge of the panel are always on the interior of the panel.

Select the first panel to be installed, typically beginning with a CORNER PANEL. Notice that the panel is labeled "Top" along with a part number indicating that when the panel is in its proper position, the labeled end will be up.

Position the corner panel in the proper location on the walk-in floor or vinyl screed assembly and, IF THE WALK-IN HAS A FLOOR, flush the corner panel with the corner of the floor panel in both directions and lock it securely to the floor panel.

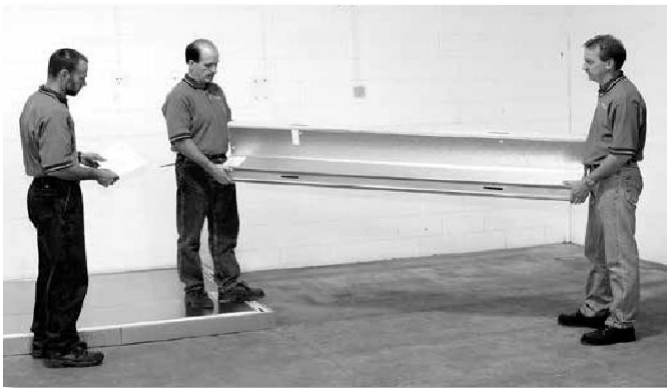
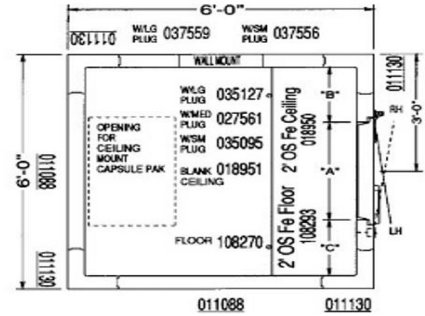
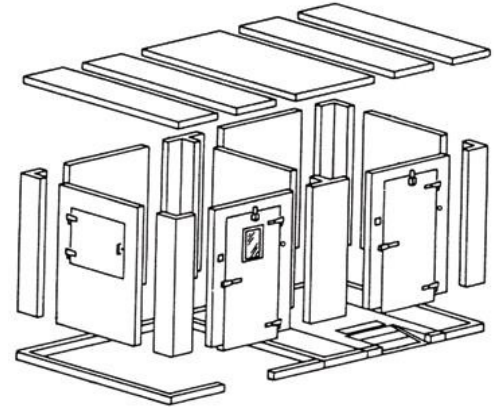

WALK-IN INSTALLATION

If the first corner panel is supported by a 1" vinyl sealer (screed), seek assistance to support the corner panel in a vertical position until succeeding wall panels are installed. Wall and corner panels do not lock to the vinyl sealer (screed).

Select the next panel as indicated on the floor plan and position it on the floor or sealer (screed) close enough to the first panel installed so that section latch engagement is possible.



Making sure that the two panels are perfectly aligned at the TOP EDGE and that the VERTICAL JOINT of the two panels are perfectly flush, turn the section latches on the vertical edge of the panel until they are completely engaged.

IMPORTANT! Confirm that the top edges of the adjoining panels are aligned perfectly.



Correct

If misalignment is encountered, merely lift the lowest panel edge while locking to achieve alignment and, when all latches are engaged, permit the locked panels to resume their normal position on the walk-in floor or sealer (screed).

DO NOT SHORT-CUT! TAKE ENOUGH TIME TO PROPERLY ALIGN ALL SECTIONS.



Misalignment

WALK-IN INSTALLATION

As each wall panel or corner panel is constructed and locked in an adjoining panel along the vertical joint, engage the section latches to the floor panels by turning the hex locking wrench **ONLY ABOUT 1/4 TURN CLOCKWISE**.



Make certain that the wall or corner panel is perfectly aligned with the floor panel or foamed sealer before engaging the section latches.



Continue constructing panels according to the part numbers shown on the floor plan, and follow, explicitly, the technique described for panel alignment.

CEILING PANELS will be constructed at specific intervals to facilitate the installation. The intermittent ceiling panel construction is scheduled to allow the ceiling panels to serve as supporting ties between opposite walls as the installation progresses.

CAUTION! DO NOT SLIDE CEILING PANELS INTO POSITION! To avoid gasket damage, elevate the ceiling section clear of the wall section while bringing it into position.

When adjoining ceiling panels are in position, adjust the exterior edges so that they are perfectly flush with one another and with the wall panels directly below them. Lock the ceiling panels securely to each other. **DO NOT LOCK** ceiling panels to wall panels at this time.

NOTE: If local conditions, such as existing building walls, make it difficult to align ceiling panels with each other from the exterior, locate a step ladder near the interior walls to visually inspect the alignment and adjust as necessary.



WALK-IN INSTALLATION

DOOR/DOOR SECTION

A standard door/door section consists basically of a single wall panel that contains an entrance door and several accessories. The electrical components contained in this panel were prewired at the factory. They include the anti-condensate door opening heater, the pilot light, and switch and a vapor proof interior light.

The door was factory installed on the door panel framing fixture, checked for squareness and for proper operation under controlled conditions.

CAUTION! While installing the door/door section, extreme care must be taken to avoid twisting the panel or handling the assembly in such a manner that it is not square when it is installed. The self-closing feature, door closure operation and a perfect gasket seal all depend a great deal upon a SQUARE and PLUMB door/door section.

After all the wall and door panels have been constructed and locked securely together and all the ceiling panels have been positioned above the wall panels, the ceiling panels have been locked securely to each other, re-check the position of the ceiling panels with respect to the wall panels.

Now lock all ceiling panels securely to the wall panels.

Recheck the position of the wall panels with respect to the floor panels and lock them securely together.

NOTE: When a 1" vinyl floor sealer (screed) is used, no attachment to the wall panels is required.



**Completed
Walk-in with floor**



**Completed Walk-in floorless- shown
with vinyl floor sealer**

WALK-IN INSTALLATION

NOTE: If, for some reason, conditions on the site prohibit the installation of the walls and ceilings in the recommended order, install the wall and ceiling panels in a logical sequence that will permit accessibility for installation of the last panel. Remember to schedule ceiling panel installation at the proper intervals to serve as supporting ties between installed wall panels.

Locate the plug buttons which were packed in the hardware bag and, after checking to make sure that the hex wrench comes to a full stop on each section latch, insert a plug button into every latch access hole.



SLAM BRACES

The door/door section frame on most floorless walk-ins will be fitted with slam braces, one on each of the interior, vertical frame members. These braces will require attachment to the building floor.

Their purpose is to positively locate the lower extremities of the door frames and prevent any movement that might occur at the point where the door frame rests on the floor sealer (screed). When 1" vinyl floor sealers are furnished, they will be notched to accommodate the slam brace location.



The slotted holes in the vertical leg of the slam brace permit adjustment in either direction to allow the slam brace to contact the building floor properly. Fasteners suitable for securing the slam braces to a concrete building floor are packed in a bag and attached to one of the slam braces. For other types of building floors, the appropriate fastener must be provided by others.

IMPORTANT! Make sure that the door/door section is PERFECTLY PLUMB before attaching the braces to the building floor. The holes in the slam brace for attachment to the building floor are intentionally round so that no shifting can occur after they are secured. Make sure the slam braces have been secured to the building floor.



The recommended hole size for PARABOLT ANCHOR is 3/8" X 2-1/4"



Install anchor



Attach slam brace with fastener provided

WALK-IN INSTALLATION

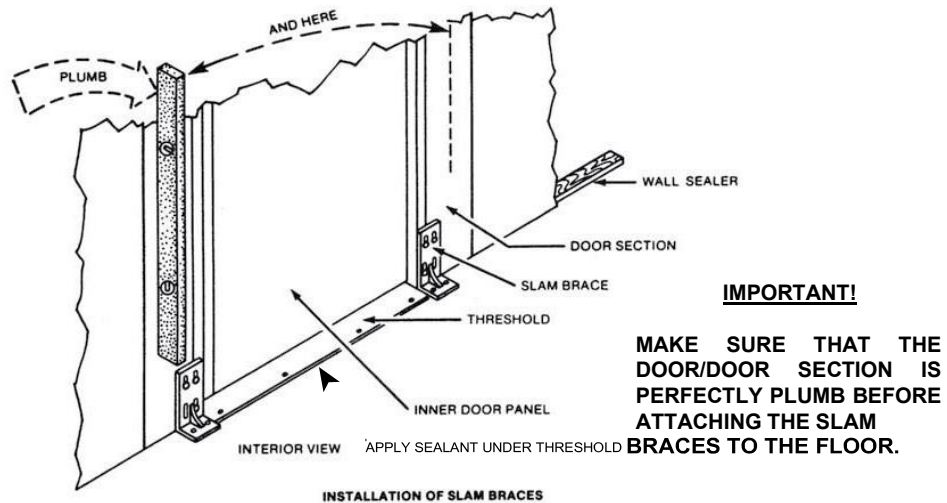

Figure 11

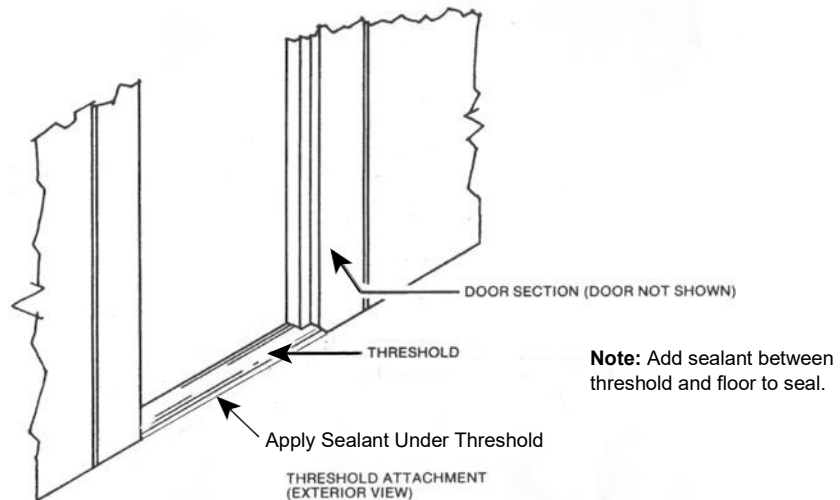

Figure 12

THRESHOLD ATTACHMENT

The threshold was attached at the factory to the lower portion of the door section and it is positioned in such a manner that no adjustment is required. It must, however, be attached to the building floor to complete the installation.

IMPORTANT! Make sure that the slam braces are securely fastened to the door section and to the building floor before attaching the threshold to the building floor. Both edges of the threshold should be attached with fasteners that are appropriate for the building floor and, since the floor surfaces vary so greatly in composition, no fasteners are provided and should be obtained by others (Figure 12).

WALK-IN INSTALLATION

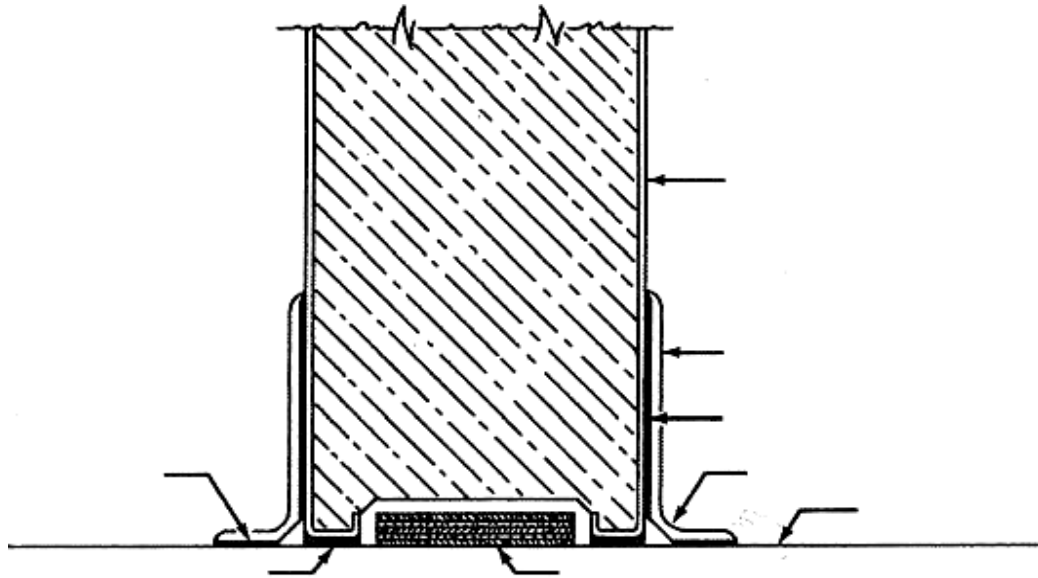

COVE MOLDING APPLIED TO A WALL PANEL WITH FEMALE-FORMED BOTTOM END

Figure 13

SEALING THE JUNCTURE OF WALLS TO BUILDING FLOOR

Apply a generous amount of NSF approved sealant to achieve a vapor seal between the bottom edge of all wall, corner, door and partition panels and the building floor. The sealant must be applied to both inner and outer edges of all perimeter walls and to both edges of partition walls where they meet the building floor. Make certain that the sealant produces a continuous, air-tight seal, without gaps, and that special care is taken to seal around the shimming material.

After the sealant has had an opportunity to set up, trim away all excess sealant flush with the edges of the walls. Touch up any areas where the sealant is not making a perfect seal (Figure 8).

COVE MOLDING

To comply with the requirements of Standard No. 7, National Sanitation Foundation, a cove molding with a minimum radius of 1/4" must be applied to cover the juncture of the walk-in walls and the building floor. For with floor models cove molding is required on exterior walls only.

Cove molding and adhesive for application are not normally provided. They are readily available at most building materials suppliers.

Before applying cove molding, make final inspection of the area that will be covered with the molding to make sure that the sealant is intact and making perfect vapor seal. If not, add sealant as required. Read and follow the instructions prepared by the manufacturer of the cove molding and the adhesive before proceeding with the installation (Figure 13).

If tile and grout are employed as floor material and, if base tile is intended to produce the cove required, make sure that the inside radius of the base tile is at least 1/4".

WALK-IN INSTALLATION

EXTERIOR RAMP INSTALLATION INSTRUCTIONS

Center ramp in front of door opening. Then using the 1-1/2" x 1-1/2" x 3-1/2" angle and screws provided, attach the ramp to the walk-in, as in the illustration below.

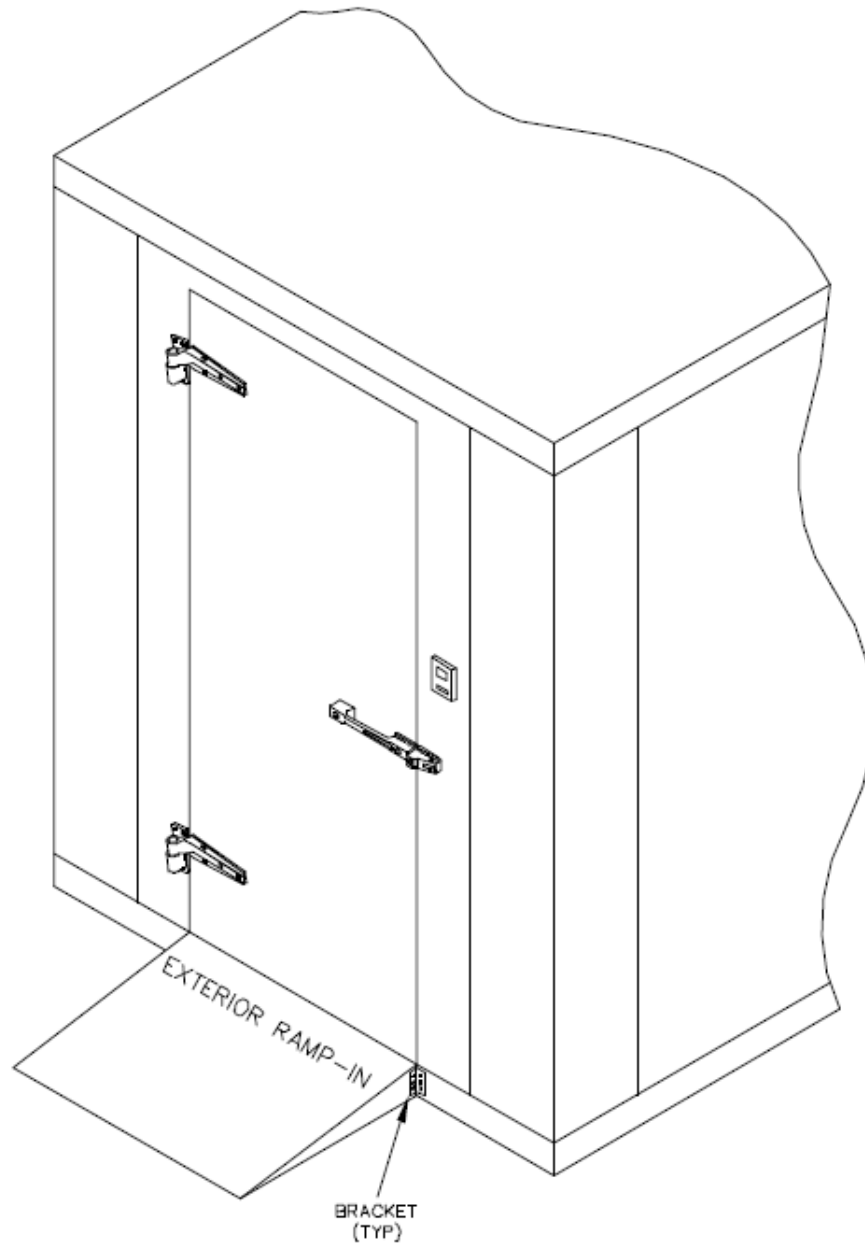

WALK-IN INSTALLATION

INTERIOR RAMP INSTALLATION INSTRUCTIONS

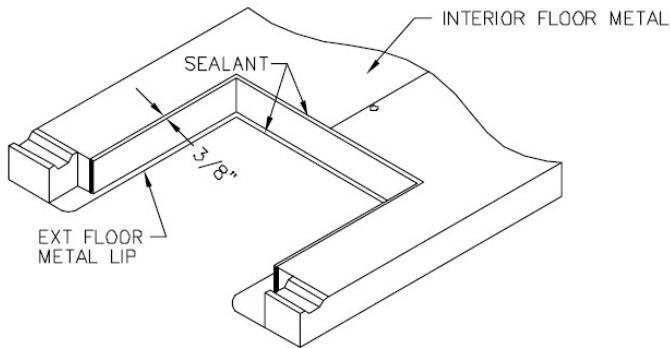

Step 1

After floor sections are in place and fully locked together, apply approximately 1/8" bead of sealant to the interior metal, 3/8" in from the ramp cut out. Also apply approximately 1/8" bead of sealant to the center of the exterior metal lip.

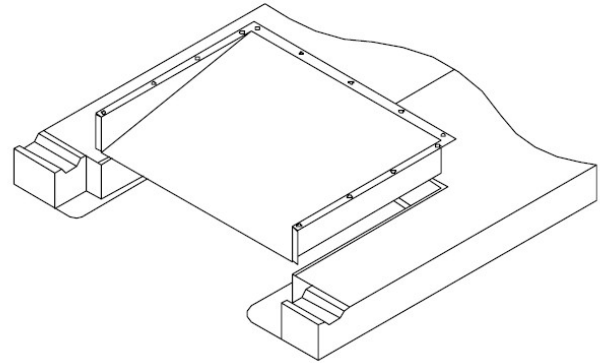

Step 2

Place ramp into position by lining up the pre-drilled holes in the ramp with those pre-drilled in the interior floor then secure the ramp into the floor with the #8 x 1/2" screws provided.

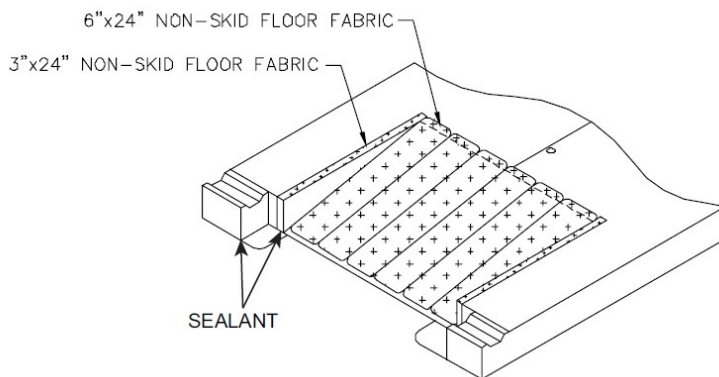

Step 3

Install the non-skid floor fabric. 6" x 24" non-skid tape strips are applied to cover the ramp and back seam of the ramp to the floor panels. 3" x 24" non-skid tape strips are applied to cover the side seams of the ramp to the floor panels.

Apply sealant where the door section meets the interior and exterior of the floor panel and ramp. Also, apply sealant under the door threshold.

WALK-IN INSTALLATION

MEMBRANE ROOF INSTALLATION INSTRUCTIONS

IMPORTANT NOTE:

IF THIS WALK-IN INCLUDES CEILING MOUNT CAPSULE-PAK™ REFRIGERATION SYSTEMS, PLEASE REFER TO CAPSULE-PAK™ REFRIGERATION INSTALLATION MANUAL. ALSO, BE SURE THE INTERIOR COIL IS HUNG CORRECTLY PER THE REFRIGERATION MANUAL INSTRUCTIONS BEFORE INSTALLING THE MEMBRANE.

Step #1

After walk-in is completely assembled, lay E.P.D.M. over ceiling topside and trim to a 6" overlap on all four sides.

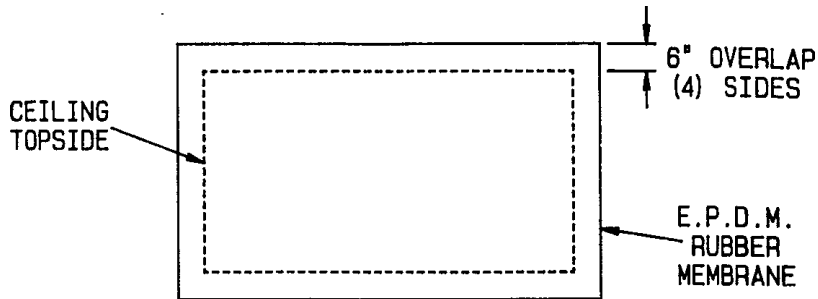

Step #2

Fold all four corners as shown below.

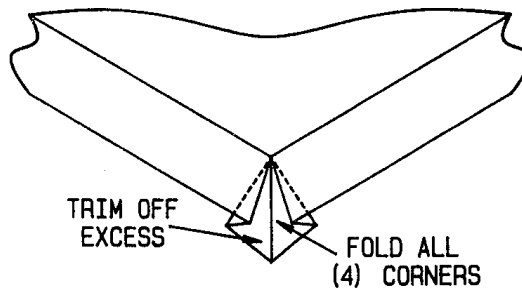

Step #3

Attach trim, refrigeration hood and door hood with sheet metal screws provided. On some models the trim may have to be cut to fit.

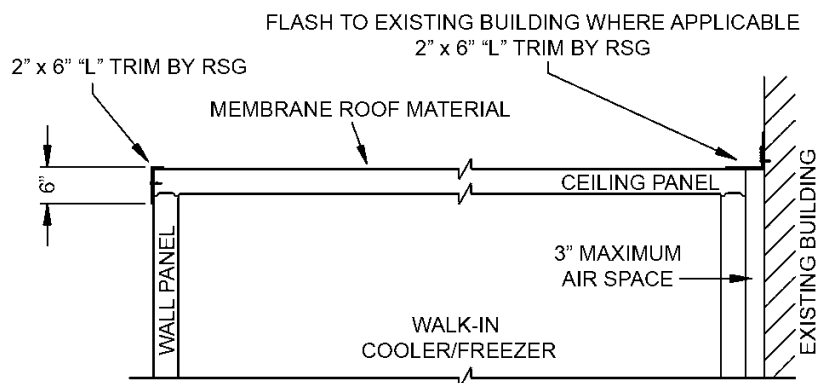

Step #4

Trim off all excess rubber membrane from under aluminum trim and hoods with utility knife. Be careful not to scratch the surface of the panels with the knife.

WALK-IN INSTALLATION

Electrical Connections

WALK-IN COOLER OR FREEZER WITH A SINGLE INTERIOR LIGHT MOUNTED ON THE DOOR SECTION

CAUTION: ELECTRICAL CONNECTIONS TO THE WALK-IN MUST COMPLY WITH APPLICABLE PORTIONS OF THE NATIONAL ELECTRICAL CODE AND ANY OTHER ELECTRICAL CODES THAT MAY HAVE JURISDICTION OVER THE INSTALLATION!

A dedicated electrical power supply circuit for the walk-in is recommended.

WARNING! DISCONNECT THE SELECTED POWER SUPPLY CIRCUIT AND ATTACH A TAG TO THE DISCONNECT SWITCH INDICATING THAT THE CIRCUIT MUST NOT BE ENERGIZED WHILE SOMEONE IS WORKING ON THE LINE.

WIRING

The cooler or freezer door panel contains several electrical components that were prewired at the factory. They include the anticondensation door opening heater, the pilot light/switch and LED interior light mounted on the door panel. **NOTE: It is the electrical contractor's responsibility to provide the necessary wiring, connections, conduit and fittings to complete the hook-up.**

The junction box adjacent to the light fixture contains the electrical leads that are prewired to the electrical components in the door section. Make your electrical connections here.



Affixed to the interior of the door section is a label which describes the electrical characteristics and the energy consumption described in watts and amperes.

WALK-IN INSTALLATION

IMPORTANT! When all field wired connections are completed in the junction box located on top of the ceiling section, be sure to **THOROUGHLY SEAL** the conduit fitting through which the wiring projects into the junction box. The silicone sealant provided is well suited for this purpose. Failure to do so will permit moisture to form within the junction box and electrical fixture(s) and potentially cause a short.

POSITIONING THE THERMOMETER SENSING BULB

For convenient monitoring of the temperature of the storage compartment of this walk-in, a remote reading thermometer has been installed in the door section at about eye level. It is a flush panel mount with an LED readout.



For optimum accuracy, the sensing bulb must be exposed to the air that is being monitored. Make certain that the sensing bulb is not positioned near the interior light or any other heat producing device, nor should it be located where stored products shield the sensing bulb from the circulating air pattern within the walk-in. The long sensing lead is more than adequate to provide an ideal sensing bulb placement on the inside surface of the door section or an adjacent wall or corner panel. When the location is finalized, an adhesive backed, plastic clip is used to secure the sensing bulb to that surface.

To prevent possible damage to the door opening heater and/or to the protective globe over the interior light, **DO NOT** energize the door/door section until the interior temperature has been reduced to the normal operating range by refrigeration. A caution label is affixed to the door section near the vapor proof light to serve as a reminder.



PRESSURE RELIEF PORT

If a pressure relief port is supplied, connect it to a 115/60/1 VAC power supply.



WIRING DIAGRAM: A wiring diagram showing the electrical components contained in the door/door section circuitry involved as shown. Always refer to the wiring diagram if it becomes necessary to replace any of the components.

WALK-IN INSTALLATION

SCIENTIFIC DOOR SECTION WIRING

STANDARD SINGLE DOOR
(EXTERIOR SWITCH ONLY)

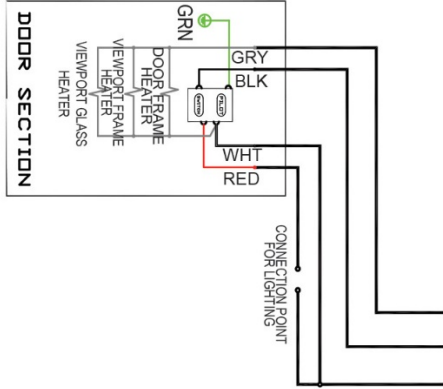

STANDARD 2 DOORS
(EXTERIOR SWITCHES ONLY)

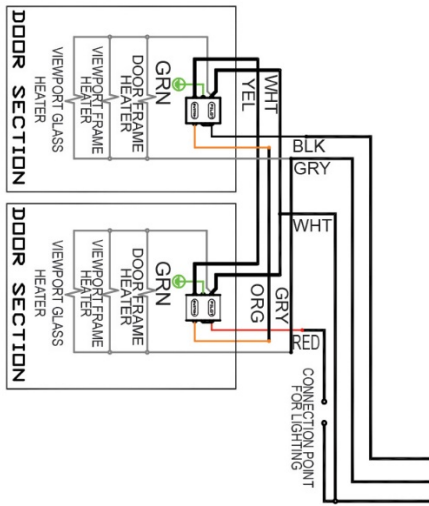

STANDARD SINGLE DOOR
W/ EXT. & INT. SWITCHES

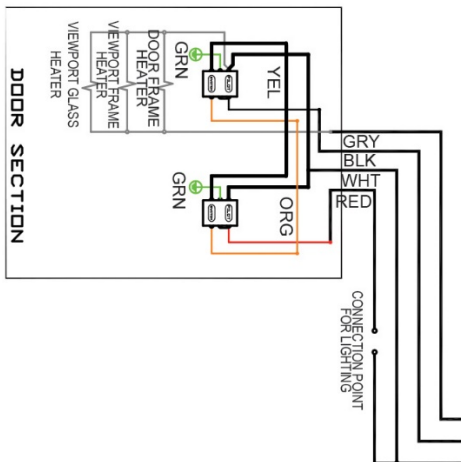

WALK-IN MAINTENANCE

ADJUSTABLE HINGE

RSG 26", 30", & 36" wide walk-in doors are provided with an adjustable hinge. The adjustable hinge provides the ability to square a door within the door jamb.

If a door requires adjustment:

Open the door and you will find a small chrome plug button, on the edge of the door behind the upper hinge. Before any adjustment you must first slightly loosen the screws on the hinge strap on the door. Then pop off the chrome plug button. Now you can access the adjustment screw. You should only make minor adjustments and then close the door to view if the adjustment rectified the situation. When complete replace the chrome plug and re-tighten the screws on the hinge strap.

NOTE: On doors with a kick plate you may have a center (3rd) hinge. In this case there is a 2nd adjustable hinge. You will need to loosen the screws on both the top and center hinge(s) and make minor adjustments in both areas.

REPLACEMENT OF THE MAGNETIC DOOR GASKET ASSEMBLY

For your convenience and safety, it is advisable to remove the entire door assembly from the walk-in cooler or freezer before attempting to replace the door gasket. Prepare a smooth, clean surface on which the exterior surface of the door assembly can be placed without marring or scratching the finish.



DOOR ASSEMBLY REMOVAL - ALL FOAMED WALK-IN COOLER OR FREEZERS WITH CAM LIFT HINGES

NOTE: For doors equipped with a spring hinge, see the door removal instructions label on the interior of the door near the top hinge. When removing the door assembly from any walk-in, solicit the aid of an assistant during the door removal and replacement procedures.

1. Open door to dwell position, stopping at approximately 120°.
2. Put mark on floor to indicate position of door, see sketch.
3. Lift door off frame.
4. To replace door, line up door with mark on floor.
5. Place hex hole in hinge straps over hex rods and lower door.

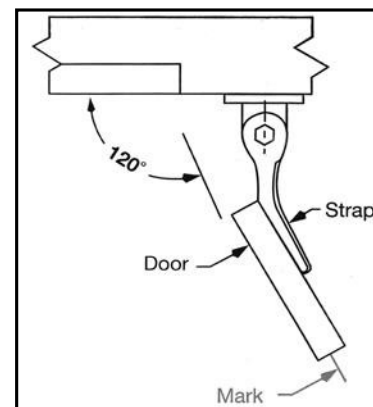

RESETTING SPRING HINGES

For the top spring-loaded hinge, you will need to reset the spring/hexagon pin. With the door installed, closed and locked, remove the screws from the spring-loaded hinge strap on the door only. You will need to hold the hinge strap against the door to prevent the strap from springing out towards you after the screws are removed. Remove the strap portion from the door by pulling upward. Hold the strap portion above the remainder of the hinge so that the strap is flat against the door. Bring the strap portion back down towards the door so that it meets the hexagon pin. You have now reset the spring. Insert the screws back into the strap and door. Note: Under normal conditions, the spring has no tension when the door is closed.

WALK-IN MAINTENANCE

DOOR GASKET REPLACEMENT

1. Place the door, exterior face down, gasket up, on a clean, smooth surface that will not mar or scratch the finish.

2. The magnetic door gasket consists of a cavity containing the magnetic strip, a bellows cavity that permits the gasket to conform to irregular surfaces, and a base section that features a dart-shaped projection that serves as the attachment means when it is forced into the slot in the door breaker.

3. To remove the original magnetic gasket assembly, grasp the gasket at one of the corners and pull the dart-shaped projection out of the retainer slot in the door breaker. Pull slowly and examine your progress to avoid tearing the projection which will then remain in the retainer slot.

4. Remove the entire gasket assembly and examine the retainer slot to make sure that it is free of gasket material or other debris.

5. Starting at one corner, insert the dart-shaped projection of the replacement gasket into the retainer slot and, using a rubber mallet, drive the dart into the retainer slot. HINT: Cover the face of the rubber mallet with masking tape to prevent smudging the gasket. Attach only about two inches (2") of the gasket in each direction away from the corner.

6. Use the same procedure as in Step 4 at the remaining corners and midway between the corners on the long sides of the door.

7. Using the rubber mallet, drive the dart into the retainer slot working from the center of each side toward the corners.

8. Lift the gasket base on the outer edge of the gasket and examine the gasket to determine if the dart is engaged by the retainer slot around the entire perimeter of the door, except where the sweep gasket is attached. If the dart has failed to engage in some areas, a small, slotted screwdriver blade can be used to tuck the dart into the slot.

9. Replace the door assembly. Simply reverse the instructions in the "Door Assembly Removal" section.



WALK-IN MAINTENANCE

SWEEP GASKET

The sweep gasket was factory installed and tested for proper operation before shipment. It features a unique cross-section designed to not only seal the gap between the bottom of the walk-in door and the threshold or building floor, but its off-set configuration closes an opening that is normally created at both ends of a conventional sweep gasket. It is attached to the lower edge of a walk-in door assembly with 3/4" pan head sheet metal screws and flat washers.

The sweep gasket extrusion consists of three distinct durometers (hardness) of vinyl extruded in a one-piece profile. The rigid area forms the attachment section. The flexible portion forms the sweep projection and provides the end seal and an extremely flexible lip that contacts the threshold or building floor, depending upon the installation.

OPERATION

As soon as the door opening sequence begins, the cam-lift hinges begin raising the door and the sweep gasket releases its contact with the threshold or building floor. At approximately 90° from the face of the walk-in, the door will reach the "hold open" position and will no longer rise by cam action. The sweep gasket will be lifted about 3/8" above the threshold or building floor.

When in the closed position, the extremely flexible lip of the sweep gasket should merely brush the threshold or building floor along its entire length.

ADJUSTING THE SWEEP GASKET

(Initial Installation)

With the door COMPLETELY CLOSED, the proper distance between the bottom of the rigid attachment area of the sweep gasket and the threshold or building floor MUST BE 1/2".

If this dimension is less than 1/2", the sweep gasket will wear prematurely and will produce excess friction for the door closer to act against during the door closing sequence.

If this dimension is greater than 1/2", the lower lip will not contact the threshold or building floor and the seal will be compromised, permitting air infiltration to occur in this area. Measure both ends of the sweep gasket with the door closed and adjust until exactly 1/2" is attained.

ADJUSTING THE SWEEP GASKET

(Normal Wear)

After considerable usage, if examination reveals that the lower lip of the sweep gasket has worn to a point where noticeable air infiltration is occurring, merely loosen the attachment screws and the lower the gasket only enough to permit the lower lip to brush the threshold or building floor while the DOOR IS IN THE CLOSED POSITION. Do not lower the gasket more than is necessary! Tighten the attachment screws and check the operation.



WALK-IN MAINTENANCE

DOOR CLOSER

The door closer was factory-installed and tested for proper operation before shipment. This small, but powerful device provides smooth and positive closing with only a minimum of attention. No lubrication of any kind is required. It is

recommended that, at least once each month, the relationship of the hook and roller to each other be examined.

To become familiar with the various components of the closer, see photo of a closer properly engaged when the walk-in door is closed.

Since the door closer is non-adjustable, any adjustment that becomes necessary must be accomplished at the closer hook.

CAUTION: DO NOT ATTEMPT TO BEND THE HOOK as a means of adjustment. The hook is formed and tempered to resist deformation during normal use.

ROLLER IS TOO LOW: Loosen all hook bracket screws and add flat washer(s) between the bracket and the header where the TOP two screws will keep them in place. Tighten the screws and check the hook position.

ROLLER IS TOO HIGH: Loosen all hook bracket screws and add washer(s) between the bracket and the header where the BOTTOM two screws will keep them in place. Tighten the screws and check the hook position.

If, for any reason, the roller arm is accidentally bumped into a vertical position while the door is open, IT MUST BE MANUALLY MOVED TO THE HORIZONTAL POSITION before the door is closed. Failure to do so may cause serious damage to the door and/or the door closer.



Correct with Door Closed

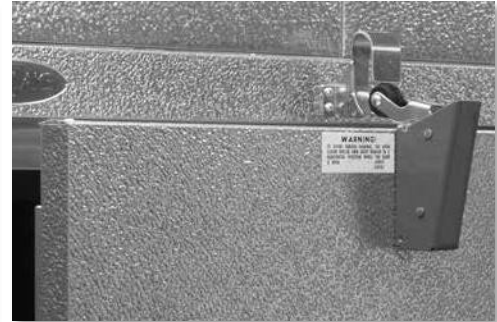

Correct with Door Open



Roller Too Low



Roller Too High



A warning label is affixed to the door section as a reminder.

WALK-IN MAINTENANCE

ANTI-CONDENSATE DOOR OPENING HEATER

To prevent condensate from forming around the outer edges of the door opening, an anti-condensate heater has been installed around the perimeter of the door opening. This constant-energy, low wattage, electric heater wire elevates the temperature of the door jambs and threshold sufficiently to maintain these surfaces above the dewpoint temperature of the surrounding air preventing condensation.

Failure of the heater wire is usually suspected when condensation forms around the perimeter of the door opening. Moisture accumulates to a point where it causes a problem on the building floor, or when the condensate freezes around the door opening, as will be the case when a walk-in freezer is involved. There is no cause for alarm, however, if occasionally a few drops of moisture form during a period of EXCEPTIONALLY HIGH HUMIDITY.

NOTE: The heater wire is designed to provide the proper amount of heat to the surfaces around the door opening WHILE THE WALK-IN IS AT DESIGN TEMPERATURE! Premature failure will result if the heater wire is energized over an extended period while no refrigeration is occurring within the walk-in cooler or freezer.

HEATER WIRE REPLACEMENT

There are two potential frames that will need three pieces of trim and the threshold removed before you can gain access to the heater wire. The trim serves as the cover of the heater raceway at the side jambs and the head jamb. The threshold covers the heater channel in the bottom plate of the door section.

Option 1



Option 2



WALK-IN MAINTENANCE

THRESHOLD REMOVAL

WARNING! Make sure that the electric power to the walk-in is disconnected before attempting to replace door heater.

To remove the threshold, remove all visible screws that attach the threshold to the walk-in floor or to the building floor. Three screws attach the threshold to the bottom plate of the door section. When all screws are removed, pry the threshold up until it is free and remove it from the floor section.



STAINLESS STEEL TRIM REMOVAL

Use a screwdriver to remove four screws on each of the three trim pieces. Remove each trim piece in turn. This will expose the heater wire and hardboard spacer strip.



WALK-IN MAINTENANCE

Again, **MAKE SURE THAT THE POWER IS DISCONNECTED** and remove the cover plate from the pilot light and switch on the front of the door section. Remove the two screws that attach the pilot light and switch assembly to the switch box and pull the pilot light and switch assembly out of the switch box enough to expose the terminal screws on the device.

Examine the wiring in the switch box and identify the two black leads from the heater wire that are connected either to two switch terminals or to one switch terminal and to a wire connector. Refer to the wiring diagram of the walk-in cooler in the "Electrical Connections" section of this manual. **HINT:** After positively identifying the two leads to the heater wire, cut the leads off, but leave an inch or two remaining on the switch terminal(s) and/or wire connector. In so doing, these short lengths of lead will positively identify the proper points of connection when the replacement heater is installed. Remove the original heater wire from the jambs and threshold and discard it.



INSTALLATION OF THE REPLACEMENT HEATER



Insert the two lead wires of the replacement heater into the access hole in the heater wire raceway that leads to the pilot light and switch junction box. **NOTE:** The section where the lead connects to the heater wire **SHOULD NOT BE BENT!** Locate the connector sections as close as possible to the access hole but **KEEP THEM STRAIGHT!** Secure the connector sections in place with a short piece of electrical tape.

Temporarily arrange the heater wire assembly.

WALK-IN MAINTENANCE



Using small pieces of electrical tape, fasten the heater wire in place. Lift the heater wire at each corner and apply three thicknesses of electrical tape around the insulation over a length of approximately 3".

Follow by forming a small loop at each corner to permit expansion and contraction of the heater wire without strain at these points. After the loops are formed, tape them in place with a short strip of electrical tape.

The heater wire should be relatively straight in the head jamb and in the side jambs, but all excess heater wire must be taken up in the THRESHOLD AREA ONLY by forming a "zig-zag" configuration. Make sure that this configuration will be accommodated by the width of the raceway in the bottom plate or threshold. The extra length of heater wire concentrated in the threshold will produce more heat per foot in the threshold than in the jambs.

After the heater wire is in place, tape it down where necessary with short strips of electrical tape to prevent the heater wire from interfering with the replacement of the chrome trim.



STAINLESS STEEL TRIM REPLACEMENT

Start replacing the stainless steel trim with the head trim section. Hold in place while replacing the three screws. Install the right and left trim in a similar manner. The trim should easily be replaced by hand.



THRESHOLD REPLACEMENT

Place the threshold in its original location and replace all the screws in their original locations. Reminder: The hardboard needs to be in place before replacing the threshold. After the threshold is secured, apply a 3/16" bead of silicone sealant at both ends of the threshold where they meet the side jambs. With a wet finger, smooth out the silicone fillet for a neat, professional looking job.

WALK-IN MAINTENANCE

ELECTRICAL CONNECTION

Referring to the wiring diagram in the "Electrical Connections" section of this manual, connect the heater wire leads as shown. If short lengths of the lead wires were left as indicators, connect the replacement heater leads to those points of connection and discard the short indicator lengths.

NOTE: If one of the heater leads connects to another wire through a wire connector, obtain a properly sized, twist-on wire connector for this purpose.

Replace the pilot light and switch in the switch box and attach the switch cover to complete the job. Energize the walk-in cooler to resume operation.

PANEL CLEANING AND MAINTENANCE RECOMMENDATIONS

During uncrating, handling and installation, the panel surfaces of your walk-in cooler or freezer may have become stained or dirty. Cleaning all metal type surfaces, door trim and gaskets can be performed with a mild detergent and hot water. It is important that you remove all excess soap and dry the surfaces thoroughly. Never, under any circumstances, use an abrasive or alkaline solution.

Occasionally it may become necessary to clean the interior surface for sanitary purposes. A mild solution of baking soda and warm water will tend to impart a clean, sweet smell to the interior should odors occur from spillage or container breakage. Never leave standing water inside the walk-in cooler or freezer.

Warning: Walk-in floor must be kept free of any liquids, food particles or any items that could cause a slip hazard. Spilled liquids, food particles or any moisture on the walk-in floor can cause the floor to become slippery. Always keep the floor surface clean and dry.

- Inspect non-skid floor strips on ramps and floor surfaces and replace if worn.
- Inspect refrigeration system, door gaskets and hardware for proper operation to prevent moisture on walk-in floor, ceiling or walls.
- Avoid leaving entry doors open for more than five minutes, which can cause a film of ice or moisture to form on floor, ceiling and wall surfaces due to the excessive condensation of warm moist air entering the walk-in. Vinyl strip curtains can be used to reduce the amount of warm moist air entering the walk-in.



FINAL CHECKLIST FOR INSTALLATION OF WALK-IN AND REFRIGERATION

Location#

Sales Order #

Dear Refrigeration Contractor:

Our goal is to supply our customers with the best equipment available. This is accomplished by combining the highest quality commercial refrigeration equipment with a craftsman like installation that meets all factory requirements. This document will help you understand and verify the installation meets these requirements.

This document is to be used in conjunction with the Installation and Operation Instruction Manual and the floor plan drawings provided with the product.

When the job is complete and equipment is running to factory specifications, the attached inspection report must be filled out completely and returned.

If there are any questions, concerns, service or parts needs, please contact Norlake at 800-388-5253 or Master-Bilt at 800-647-1284. Please have the equipment model number and serial number at the time of your call.

Things to Verify When Inspecting an Installation:

(Shaded areas to be filled out by the installing refrigeration contractor)

Walk-In	Yes	No	Repairs Made	GC Review *
1. Were any components that were to be supplied by RSG missing from the delivery? Verify all the components delivered to the job site match the packing list.				
2. Is the surface that the walk-in is to be installed upon smooth and level to within plus or minus 1/2" over the length of the slab? (It is recommended a string level or laser level be used to verify the slab meets these requirements.) The walk-in shall not be installed if the levelness of the slab does not meet these requirements.				
3. Was the 6 ml polyethylene film vapor barrier installed prior to the floorpanels being installed?				
4. Is the walk-in centered in the space provided with a minimum of 2" clearance between the walk-in and building walls on each side?				
5. Are the cavities between the building envelope and walk-in external walls free of debris and remain unobstructed?				
6. Are there any damaged panels or other components, dents or unsightly scratches in the supplied walk-in floor, wall or ceiling panels?				
7. Is the base of the walk-in caulked around the perimeter?				
8. Are all the wall panels level across the top? Are walls plumb and ceiling level?				
9. Are there any gaps identified between wall panels following engagement of the lock and strike? The panel gasket must be in contact with the metal edges of both panels.				
10. Is the door section and door plug plumb and level? Does the door close properly? (Verify door closing by opening the door to 90°. Door must close and seal without any assist).				

FINAL CHECKLIST FOR INSTALLATION OF RSG WALK-IN AND REFRIGERATION

<p>11. Are the lights installed, connected to the light switch and operating correctly?</p> <p>12. Have all electrical and other penetrations been properly sealed as recommended?</p> <p>13. Is the temperature sensor extended away from door and mounted on the wall?</p> <p>14. Is the strip curtain mounted in place and secured?</p> <p>15. Are the refrigerant piping and electrical cable supported and strain free?</p> <p>16. Is the serial tag correctly installed?</p> <p>17. Has the surplus construction material been removed from the top of the walk-in?</p> <p>18. Does the installation look professional?</p>		
---	--	--

Note: RSG recommends pictures be taken after the installation is complete.

- 1). Exterior door section (full view)
- 2). Evaporator section (after installation)
- 3). Condensing Unit (after installation)

Final Inspection of the Walk-in and Refrigeration Systems	Yes	No	Repairs Made	GC Review *
Have the installation and maintenance manuals, wiring diagrams and other walk-in documents been turned over to the end user?				

Walk-In Model Number(s) _____

Walk-In Serial Number (s) _____

By signing below the installer hereby certifies that the installation has been completed in compliance with RSG standards and specifications. Items found not in compliance will be corrected by the installing contractor at no charge.

Refrigeration / Installation Contractor Name: _____

Refrigeration / Installation Contractor Signature: _____ Date: _____

General Contractor Name: _____

General Contractor Signature: _____ Date: _____

Contact Technical Department:

Norlake: 800-388-5253

Master-Bilt: 800-684-8988

Refrigerated Solutions Group
891 County Road U
Hudson, WI 54016

800-955-5253 Norlake Foodservice Sales
800-477-5253 Norlake Scientific Sales
800-388-5253 Norlake Parts/Service
877-503-5253 Norlake Walk-In Installation

800-647-1284 Master-Bilt Sales
800-684-8988 Master-Bilt Parts/Service