

SST-60

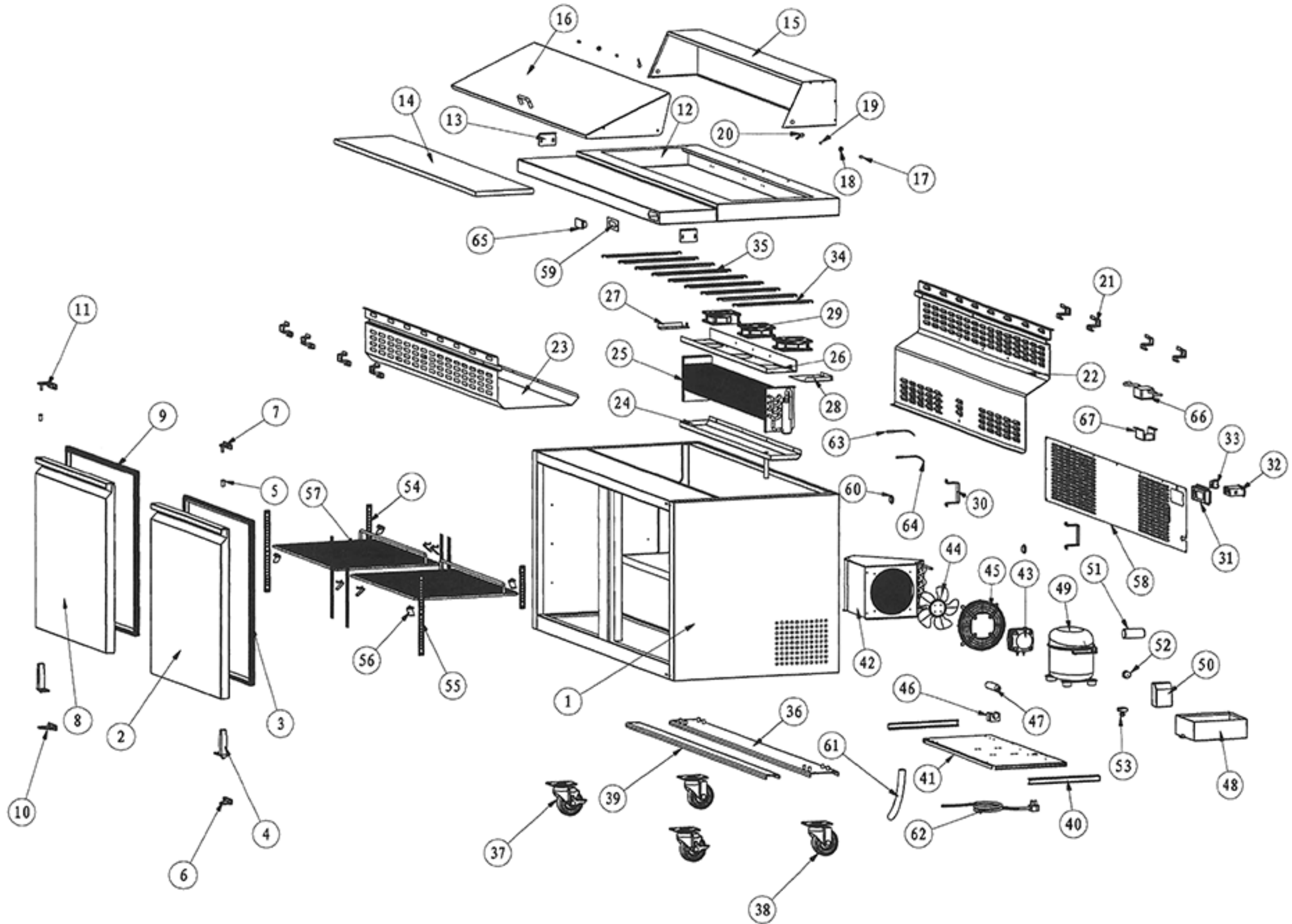

Part #	Part Name	Part Qty
1	Cabinet	1
2	Right Door	1
3	Gasket	2
4	Spring Hinge	2
5	Hinge Axis	4
6	Bottom Right Hinge	1
7	Upper Right Hinge	1
8	Left Door	1
9	Gasket	2
10	Bottom Left Hinge	1
11	Upper Left Hinge	1
12	Top Board	1
13	Fixer For Cutting Board	2
14	Cutting Board	1
15	Back Cover	1
16	Lid	1
17	Dowel	2
18	Plastic Bolt	2
19	Nut	2
20	Split Pin	2
21	Air Duct Support	8
22	Evaporator Cover	1
23	Air Return Cover	1
24	Inner Drain Pan	1
25	Evaporator	1
26	Fan Motor Installation Panel	1
27	Left Clapboard Of Evaporator	1
28	Right Clapboard Of Evaporator	1
29	Evaporator Fan Motor	3&4
30	Stand Off Bracket	2
31	Thermostat Installation Box	1
32	Thermostat	1
33	Power Switch	1
34	Pan Bracket – 15mm	2
35	Pan Bracket – 25mm	7&8
36	Castor Support	1
37	4" Castor With Brake	2

38	4" Castor	2
39	Installation Board Support	1
40	Compressor Unit Track	2
41	Compressor Unit Installation Board	1
42	Condenser	1
43	Condenser Fan Motor	1
44	Condenser Fan Motor Blade	1
45	Condenser Fan Motor Cover	1
46	Filter Fixer	1
47	Filter	1
48	Outer Drain Pan	1
49	Compressor	1
50	Splice Box	1
51	Start Capacitor	1
52	Overload Capacitor	1
53	Starter	1
54	K Strip -2 Holes	4
55	K Strip -3 Holes	4
56	K Clip	8
57	Shelf	2
58	Back Grill	1
59	Fahrenheit Temp Display Installation Board	1
60	Foaming Hole Cover	2
61	Drain Tube (16mm)	1
62	Power Cord	1
63	Temperature Sensor 1 (Thermostat)	1
64	Temperature Sensor 2 (Fahrenheit Temp Disp)	1
65	Fahrenheit Temp Display	1
66	Transformer For Fahrenheit Temp Display	1
67	Transformer Holder	1
68	Pan Bracket -108mm	1

TECHNICAL DATA

Dimensions

Exterior Dimensions (WxDxH)	60" x 29.5" x 42.5"
Interior Dimensions Top (WxDxH)	56.25" x 13.5" x 8.5"
Interior Dimensions Bottom (WxDxH)	56" x 19.5" x 24"
Cutting Board Dimensions (WxDxH)	60" x 11.5" x .75"
Net Volume (cu. ft.)	15 cu. ft.
Gross Weight	306 lbs
Packaging Dimensions (WxDxH)	65" x 34.5" x 46.5"
Electrical Cord Length	98.5"

Cooling

Temperature Range	33° - 40° F
Refrigerant	R290
Maximum Ambient Temperature Rating	90° F
Defrosting	Automatic
Temperature Display	Yes
Temperature Controller	Digital
H/P	1/2

Construction

Exterior Material	430 series stainless steel
Interior Material	304 series stainless steel
Insulation Material	Foamed in place polyurethane
Shelf Material	Plastic coated steel
Shelf Load Capacity	90 lbs

*Does not include pans

Electrical

Voltage	120
Amps	8.3
Hz	60

PLAN VIEW

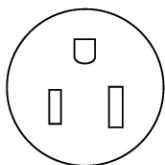
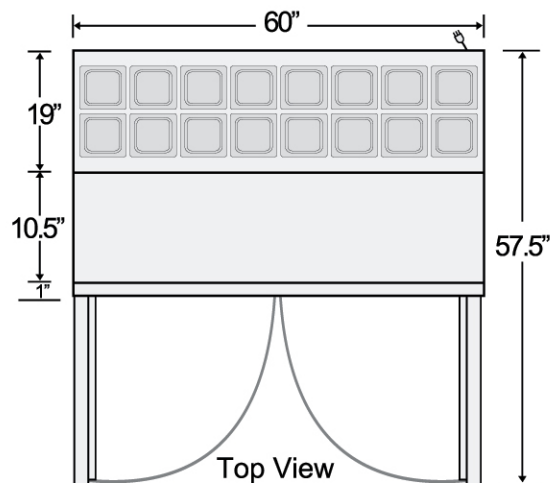
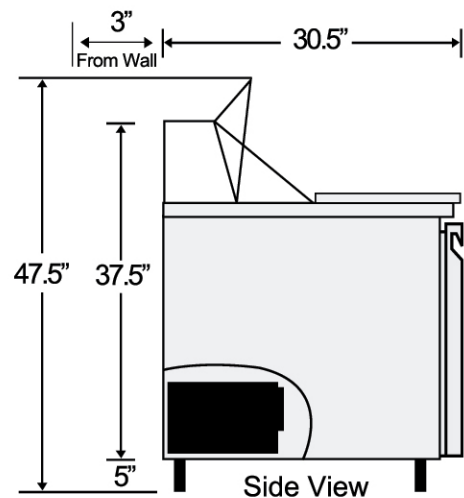
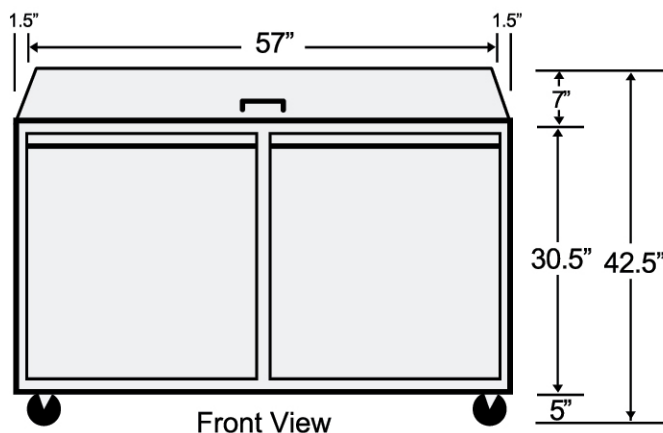

NEMA 5-15