

TECHNICAL DATA

Dimensions

Overall Dimensions (WxDxH)	30" x 32.6" x 67.6"
Machine Dimensions (WxDxH)	30" x 24.3" x 22.4"
Bin Dimensions (WxDxH)	30" x 32.7" x 45.3"
Output (lb/24hr)	500 lbs
Bin Capacity	275 lbs
Net Weight (Machine)	144 lbs
Gross Weight (Machine)	155 lbs
Net Weight (Bin)	100 lbs
Gross Weight (Bin)	111 lbs
Packaging Dimensions (Main Machine) (WxDxH)	33.2" x 29.5" x 24.4"
Packaging Dimensions (Ice Bin) (WxDxH)	33.4" x 35" x 41.5"
Ice Cube Size half cube	.86"x.86".86"

Construction

Exterior Material	304 series stainless steel
Interior Material	Polyethylene
Water Filter Capacity	2.2 GPM

Cooling

Refrigerant	R290
Temperature Display	Yes
Temperature Controller	Digital
Condenser Unit	Air
Compressor	Secop

Electrical

Voltage	115
Power	1113W
Hz	60

PLAN VIEW

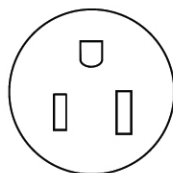
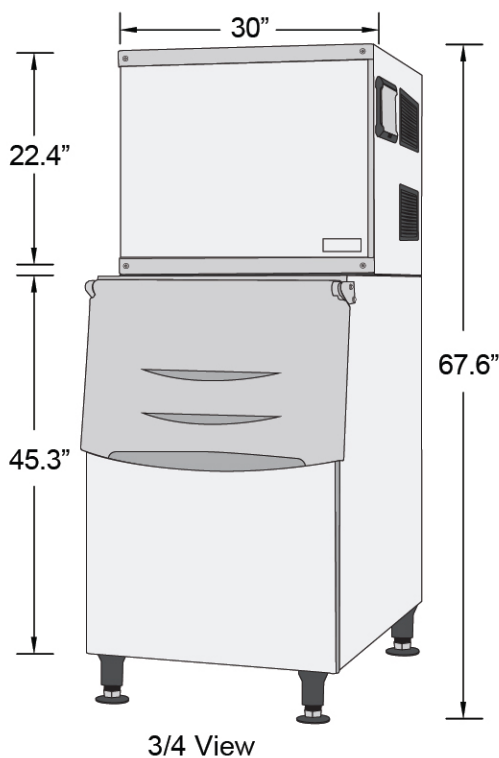

NEMA 5-15P

SMIM-500

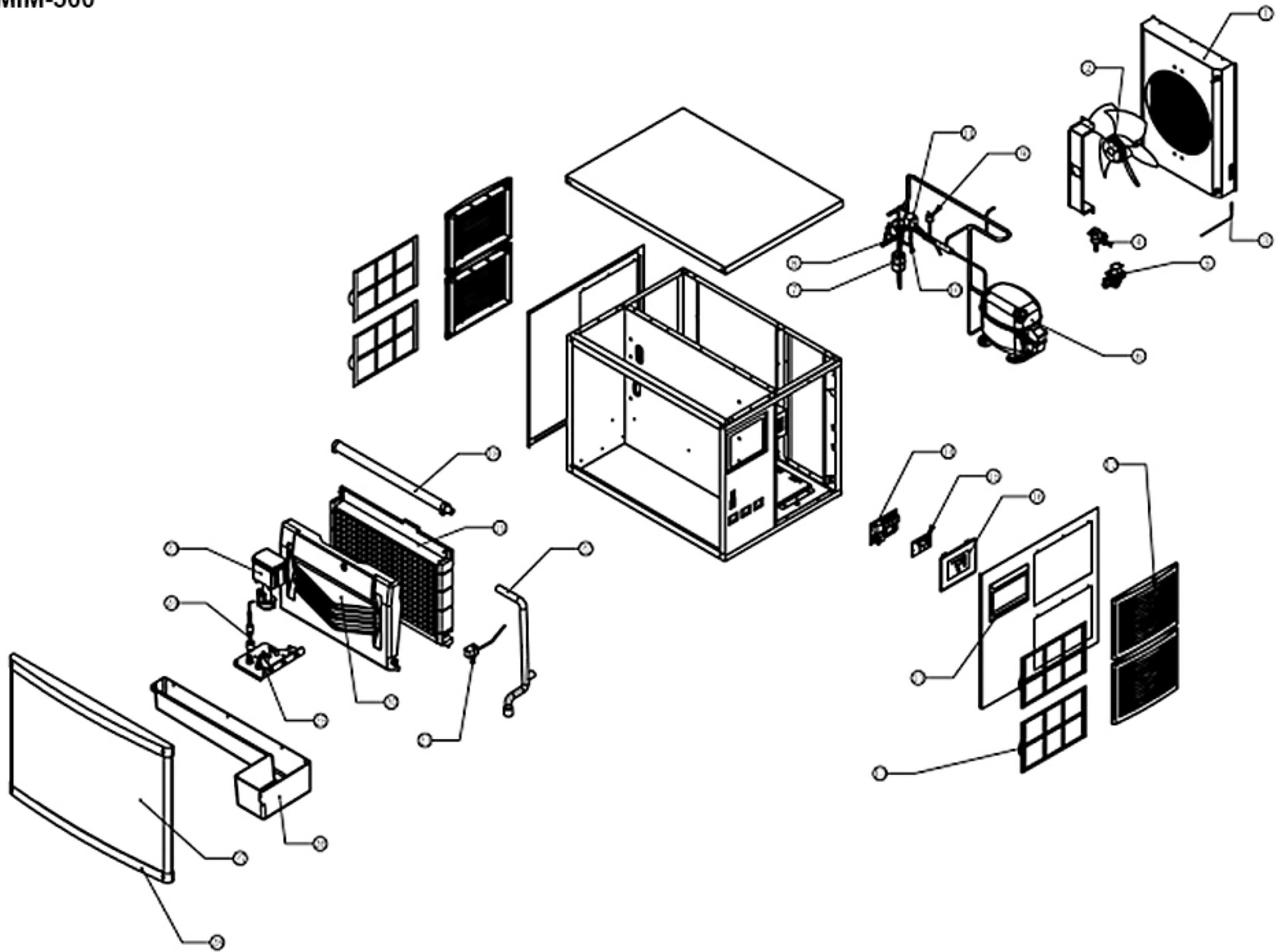

NO.	Part Name	Factory Part NO.
1	MICROCHANNEL CONDENSER	03.005.042
2	FAN	03.006.021
3	CONDENSATION SENSOR	04.010.008
4	INLET VALVE	04.003.008
5	DRAIN VALVE	04.002.006
6	COMPRESSOR	03.001.092
7	DRY FILTER	02.006.002
8	EXPANSION VALVE	04.004.018
9	HIGH VOLTAGE SWITCH	03.017.018
10	DEFROST VALVE BODY	04.005.003
11	DEFROST VALVE COIL	04.007.006
12	PLASTIC WINDOW FILTER	05.015.003
13	VENTILATION WINDOW FILTER	05.016.005
14	PC BOARD	03.011.038
15	DISPLAY PANEL	03.012.043
16	ELECTRICAL CONTROL FIXING PLATE	05.006.004
17	CONTROL PANEL COVER	05.005.002
18	SPRAY PIPE (PARTS OF EVAPORATOR)	SL.FB.32480661.00
19	EVAPORATOR	03.003.013
20	SKATEBOARD (PARTS OF EVAPORATOR)	SL.FB.32479807.00
21	ICE FULL SENSOR	03.013.009
22	UPPER WATER PIPE	09.001.002
23	WATER PUMP	03.010.001
24	WATER LEVEL WATER TEMPERATURE SENSOR	04.010.016
25	SINK PUMP FIXING PLATE	05.002.001
26	SINK	05.001.002
27	FRONT PANEL	05.018.002
28	DOOR PLASTIC END CAP	BJ.FB.75630052.00