

TECHNICAL DATA

Dimensions

Exterior Dimensions (WxDxH)	47.25" x 29.5" x 35.5"
Interior Dimensions (WxDxH)	42.5" x 19.5" x 24"
Net Volume (cu. ft.)	12 cu. ft.
Gross Weight	291 lbs
Packaging Dimensions (WxDxH)	50" x 32.5" x 38"

Cooling

Temperature Range	33° - 40° F
Refrigerant	R290
Maximum Ambient Temperature Rating	90° F
Defrosting	Automatic
Temperature Display	Yes
Temperature Controller	Digital
H/P	1/4

Construction

Exterior Material	430 series stainless steel
Interior Material	304 series stainless steel
Insulation Material	Foamed in place polyurethane
Shelf Material	Plastic coated steel
Shelf Load Capacity	90 lbs

Electrical

Voltage	120
Amps	4.8
Hz	60
Phase	1

PLAN VIEW

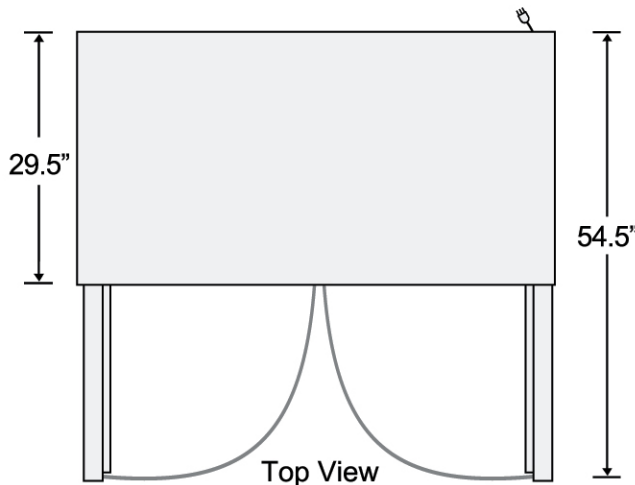
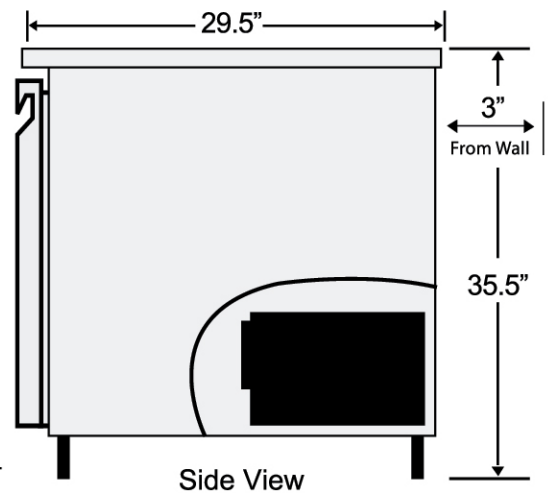
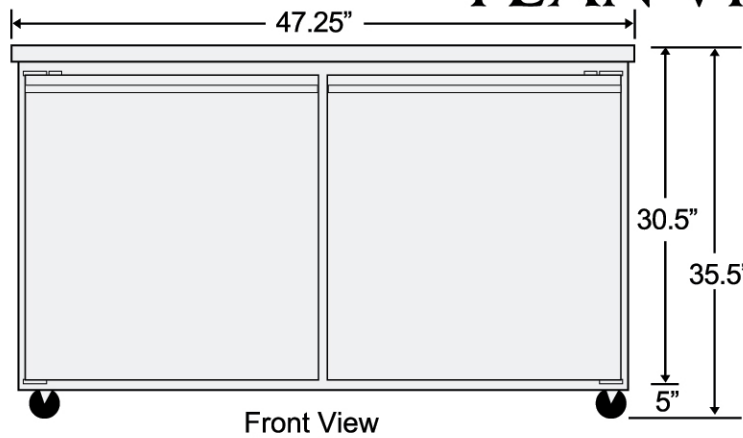

COMPLIES WITH ANSI/NSF 7 FOR FOOD SERVICE

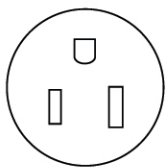

NEMA 5-15

SUR-48

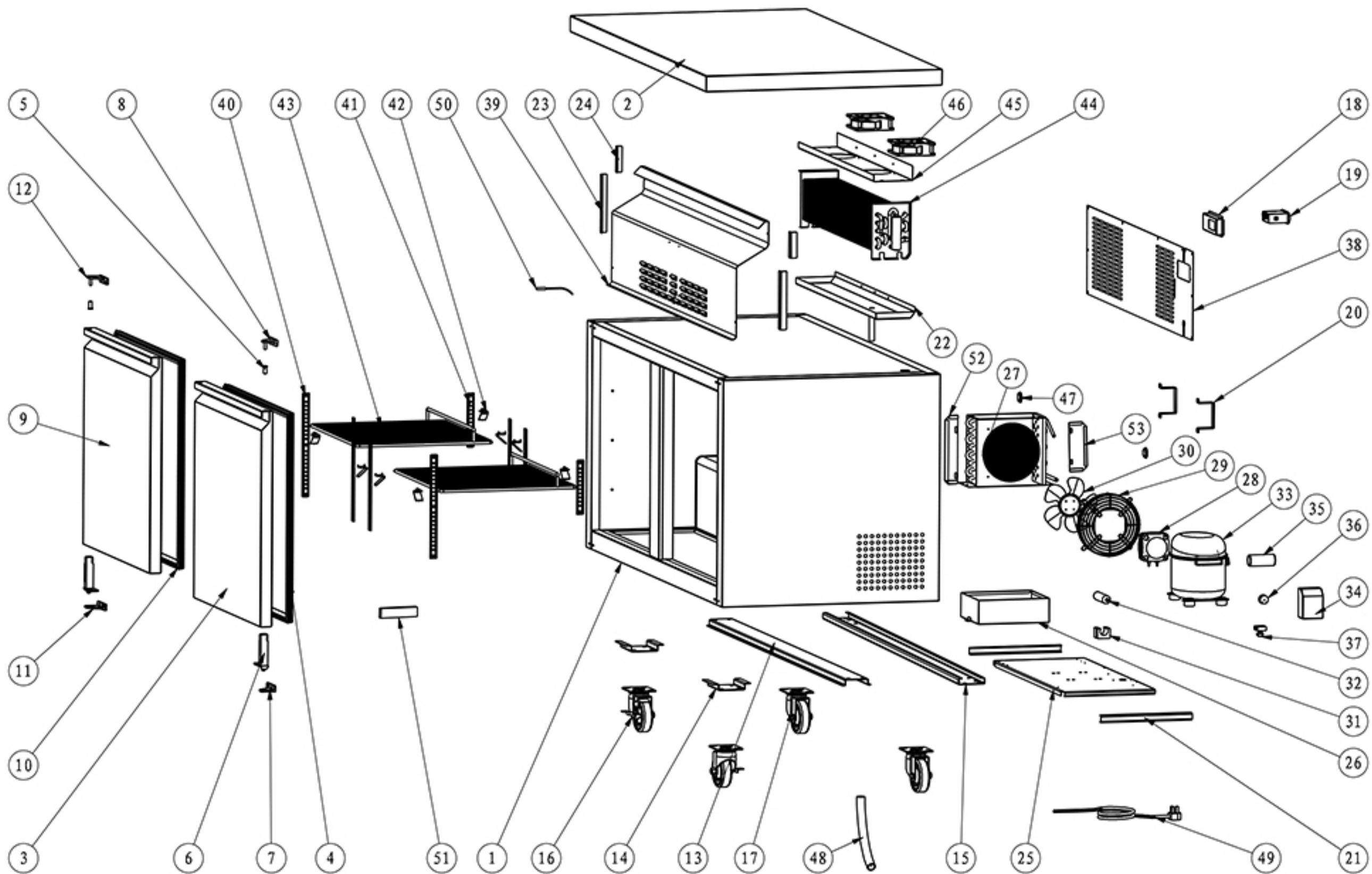

NO.	Part Name	Factory Part NO.	QTY
1	CABINET		1
2	TOP BOARD		1
3	RIGHT DOOR		1
4	GASKET	16401547635	1
5	AXIS COVER	16353010008	2
6	SPRING HINGE BOARD	12517010001	2
7	BOTTOM RIGHT HINGE	12517140005	1
8	UPPER RIGHT HINGE	12517140004	1
9	LEFT DOOR		1
10	GASKET	16401547635	1
11	LEFT BOTTOM HINGE	12517140003	1
12	UPPER LEFT HINGE	12517140002	1
13	CASTOR SUPPORT B		1
14	CASTOR SUPPORT C		1
15	CASTOR SUPPORT A		1
16	4" CASTOR WITH BRAKE	12533070420	2
17	4" CASTOR	12533040420	2
18	THERMOSTAT INSTALLATION BOARD		1
19	THERMOSTAT	17505180005	1
20	STAND OFF BRACKET		2
21	COMPRESSOR UNIT TRACK		2
22	INNER DRAIN PAN		1
23	EVAPORATOR COVER STICKER		2
24	EVAPORATOR COVER STICKER		2
25	COMPRESSOR UNIT INSTALLATION BOARD		1
26	OUTER DRAIN PAN	16316130008	1
27	CONDENSER	17303080201	1
28	CONDENSER FAN MOTOR	22752520003	1
29	CONDENSER FAN COVER	22726010001	1
30	BLADE OF CONDENSER FAN MOTOR	16381738052	1
31	FILTER FIXER	16369690257	1
32	FILTER	17111250198	1
33	COMPRESSOR	17202163117	1
34	SPLICE BOX		1
35	START CAPACITOR		1
36	OVERLOAD PROTECTOR		1
37	STARTER		1
38	BACK GRILL		1
39	EVAPORATOR COVER		1
40	K STRIP-3 HOLES		4
41	K STRIP-2 HOLES		4

42	K CLIP		8
43	SHELF	12502114352	2
44	EVAPORATOR	17405050798	1
45	FAN MOTOR INSTALLATION BOARD		1
46	EVAPORATOR FAN MOTOR	1003001114715	2
47	FOAMING HOLE COVER	16352020002	2
48	DRAIN HOSE	15809080016	1
49	POWER CORD	17664640051	1
50	TEMPERATURE SENSOR OF CABINET INSIDE	17649490013	1
51	THERMOMETER	17799990002	1
52	CONDENSER_END_PLATE_LEFT		1
53	CONDENSER_END_PLATE_RIGHT		1