

READ AND SAVE THESE INSTRUCTIONS



INSTALLATION AND OPERATING MANUAL

P/N 99399

SELF-CONTAINED REFRIGERATED SERVICE/SELF-SERVICE MODEL CO2739R



Model CO2739R Shown With Product For Illustrative Purposes Only



Structural

Concepts 888 E. Porter Road · Muskegon, MI 49441 Phone: 231.798.8888 Fax: 231.798.4960 www.structuralconcepts.com

TABLE OF CONTENTS

OVERVIEW / TYPE / COMPLIANCE / WARNINGS / PRECAUTIONS / PLUGS / WIRING	3-4
SHIPPING SUPPORT REMOVAL / GRILLE & TOE-KICK REMOVAL / REMOVING CASE FROM SKID.....	5
CASE PLACEMENT / CASTER LOCKING & UNLOCKING OPERATION / START-UP AND OPERATION	6
MAINTENANCE FUNDAMENTALS: FRONT PANEL / FRONT GRILLE / LIGHT FIXTURE	7
MAINTENANCE FUNDAMENTALS, CONTINUED: HONEYCOMB AIR DIFFUSERS	8
ELECTRICAL FUNDAMENTALS	9
REFRIGERATION FUNDAMENTALS	10
SERIAL LABEL LOCATION & INFORMATION LISTED / TECH INFO & SERVICE	11
TROUBLESHOOTING - GENERAL	12
TROUBLESHOOTING - CONDENSING SYSTEM [TRAINED SERVICE PROVIDERS ONLY]	13
TROUBLESHOOTING - EVAPORATOR SYSTEM [TRAINED SERVICE PROVIDERS ONLY]	14
ILLUSTRATED PARTS BREAKDOWN	15
PARTS LIST	16
CLEANING SCHEDULE	17
CAREL® TEMPERATURE CONTROLLER INFORMATION	18-20
JOHNSON CONTROL® - MR3CCUHV Alarm and Fault Codes	21
JOHNSON CONTROL® - MR3CCUHV Programming Control Module	22
SCC TECHNICAL SERVICE CONTACT INFORMATION & WARRANTY INFORMATION	23

OVERVIEW

- These Structural Concepts merchandisers are designed to merchandise pre-chilled packaged products at 41 °F [5 °C] or less product temperatures.
- Cases should be installed and operated according to this operating manual's instructions to insure proper performance.
- Improper use will void warranty.

TYPE I vs. TYPE II ENVIRONMENTAL CONDITIONS

This unit is designed for the display of products in ambient store conditions where temperature and humidity are maintained within a specific range.

- Type I display refrigerators are intended for use in an area where environmental conditions are controlled and maintained so that the ambient temperature does not exceed 75 °F (24 °C) and 55% maximum humidity.

- Type II display refrigerators are intended for use in an area where environmental conditions are controlled and maintained so that the ambient temperature does not exceed 80 °F (27 °C) and 55% maximum humidity.
- If unsure if your unit is Type I or II, see tag next to serial label. See **SERIAL LABEL LOCATION & INFORMATION LISTED / TECH INFO & SERVICE** section in this manual for sample serial labels.

COMPLIANCE

- Performance issues when in violation of applicable NEC, federal, state and local electrical and plumbing codes are not covered by warranty.
- See below compliance guideline.

WARNINGS

- This sheet contains important warnings to prevent injury or death. Please read carefully!



COMPLIANCE
This equipment **MUST** be installed in compliance with all applicable NEC, federal, state and local electrical and plumbing codes.



WARNING
Risk of electric shock. Disconnect power before servicing unit.
CAUTION! More than one source of electrical supply is employed with units that have separate circuits.
Disconnect ALL ELECTRICAL SOURCES before servicing.



WARNING
Hazardous moving parts. Do not operate unit with covers removed.
Fan blades may be exposed when deck panel is removed.
Disconnect power before removing deck panel.



WARNING
Condenser Pan is Hot!
Disconnect and allow to cool before cleaning or removing from case.



WARNING: This product can expose you to chemicals, including Urethane (Ethyl Carbamate), which are known to the state of California to cause cancer and birth defects or other reproductive harm. For more information go to P65Warnings.ca.gov.

PRECAUTIONS

- This sheet contains important precautions to prevent damage to unit or merchandise.
- Please read carefully!
- See previous page for specifics on **OVERVIEW**, **TYPE**, **COMPLIANCE** and **WARNINGS**.

WIRING DIAGRAM

- Each case has its own wiring diagram folded and in its own packet.
- Wiring diagram placement may vary; it may be placed

near ballast box, field wiring box, raceway cover, or other related location.

REFRIGERANT DISCLOSURE STATEMENT

- This equipment is prohibited from use in California with any refrigerants on the "List of Prohibited Substances" for that specific end-use, in accordance with California Code of Regulations, title 17, section 95374.
- This disclosure statement has been reviewed and approved by Structural Concepts and Structural Concepts attests, under penalty of perjury, that these statements are true and accurate.



CAUTION! LAMP REPLACEMENT GUIDELINES
 LED lamps reflect specific size, shape and overall design. Any replacements must meet factory specifications. Fluorescent lamps have been treated to resist breakage and must be replaced with similarly treated lamps.

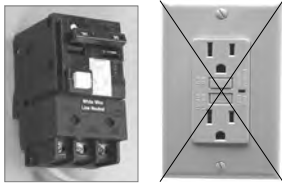

CAUTION! GFCI BREAKER USE RECOMMENDATION
 If N.E.C. (National Electric Code) or your local code requires GFCI (Ground Fault Circuit Interrupter) protection, the use of a GFCI breaker is strongly recommended.

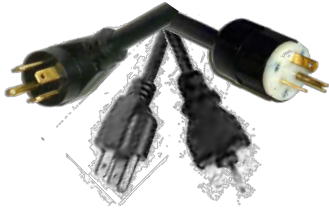

CAUTION! POWER CORD AND PLUG MAINTENANCE
 Risk of electric shock. If cord or plug becomes damaged, replace only with cord and plug of same type.

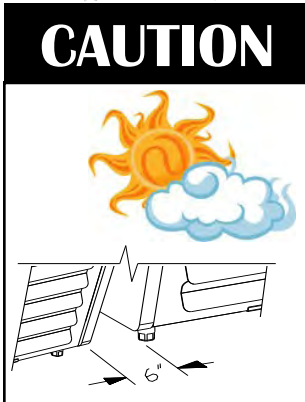

CAUTION! ADVERSE CONDITIONS / SPACING ISSUES

- Performance issues caused by adverse conditions are NOT warranted.
- End panels must be tightly joined or kept at least 6-inches away from any structure to prevent condensation.
- Unit must be kept at least 15-feet from exterior doors, overhead HVAC vents or any air curtain disruption to maintain proper temperatures.
- Unit must not be exposed to direct sunlight or any heat source (ovens, fryers, etc.).
- Keep at least 8-inch clearance above unit for air discharge (self-contained units only).

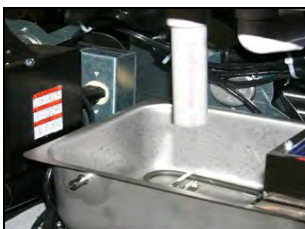

CAUTION! CHECK EVAPORATOR PAN POSITION AND PLUG
 Water on flooring can cause extensive damage!
 Before powering up unit, check the following:

- Evaporator pan **MUST BE** positioned directly under condensate drain.
- Evaporator pan plug **MUST BE** securely plugged into receptacle.

SHIPPING SUPPORT REMOVAL / GRILLE & TOE-KICK REMOVAL / REMOVING CASE FROM SKID

1. Removing Caster Shipping Support (or Shipping Support Bracket) Attached To Skid

- Remove screws holding shipping supports (or shipping support brackets) to skid. Discard.
- **Note:** Shipping supports and/or brackets will vary in size, shape, material and location depending upon case type and model.
- See illustration below-left.

2. Remove Front Grille, Rear Grille and Side Panels Before Removing From Skid

- Grilles and lower side panels may be attached to case during shipment.
- If they are attached to case, they must be removed prior to skid removal.
- Screw removal may be required.
- After case is in position (and level and plumb, if case has levelers), you must reattach these components to case.

3. Remove Case From Skid

- To prevent damage, support case (while sliding it toward edge of skid).
- For units with casters, casemay be rolled off skid

via ramp (as shown below-right) and into position.

- For units with legs/levelers, carefully slide case off skid (at one end). Then slide skid out from under case at other end (as shown immediately below).
- Use adjustable wrench and/or pry bar to level.
- Case must be level & plumb after it is in position.

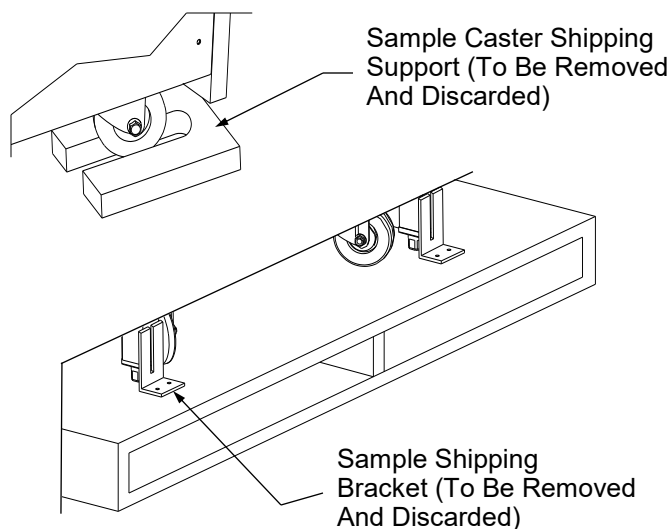
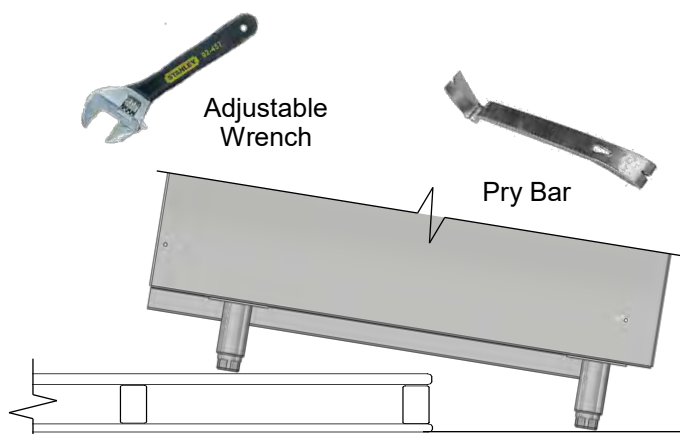

Side View of Case (With End Panel Removed For Illustrative Purposes Only)

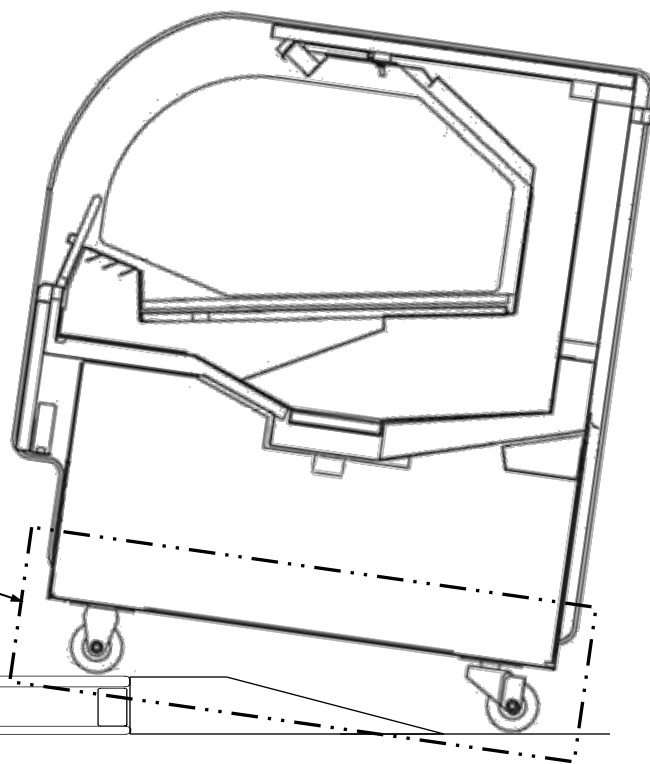

Note: Front Grille, Rear Grille and Side Panels Must Be Removed Prior To Skid Removal To Prevent Damage To Components!

1. Caster Locking / Unlocking Operation

- After case has been moved to proper location, if casters have locking feature, they may be locked to prevent case from moving out of position.
- To lock caster (from the unlocked position), press down on each RAISED caster lever (as shown in illustration below-left). Casters will lock in place.
- To unlock casters (from the locked position), press down on the RAISED caster lever (as shown in illustration below-left). Casters will now be unlocked.

2. Merchandiser Start-Up and Operation

- Do not use an extension cord with this appliance.
- Do not operate this equipment with a damaged cord, plug or outlet.
- Insure the main power switch is off.
- Plug cord into a certified 120V electrical outlet with ground.
- Turn main power on.
 - Remove upper front panel (see maintenance for panel removal). Switch is on the right side of case.
- Coil fan should turn on.
 - From inside of the case, check for discharge air from front baffle, to confirm that the fans are functioning properly.
 - When the case is in a start up mode or has been idle for a long period of time,

- the unit will require 75 minutes in order to pull -down temperature.
- The lights should come on at the same time.
 - First time lighting may require a short warm up period for the bulbs. Slightly dim or a flickering of new bulbs is normal.
- It is recommended that the self contained refrigerated cases maintain front and rear airflow clearance of approximately six inches.
- Obstruction or restriction of air can void warranty.
- The interior case temperature reaches 2 °C to 5 °C / 35 °F to 41 °F.
 - **Note:** The case temperature is set at the factory, as determined by the case size. The temperature is controlled by a thermostat. If a temperature setting change is required, refer to the instructions for the Temperature Control Programming operating section of this manual.
 - **Note:** Set point should be 4.5 °C / 40 °F. This will maintain the product temperature range. Settings lower than 4.5 °C / 40 °F can cause food items to freeze.

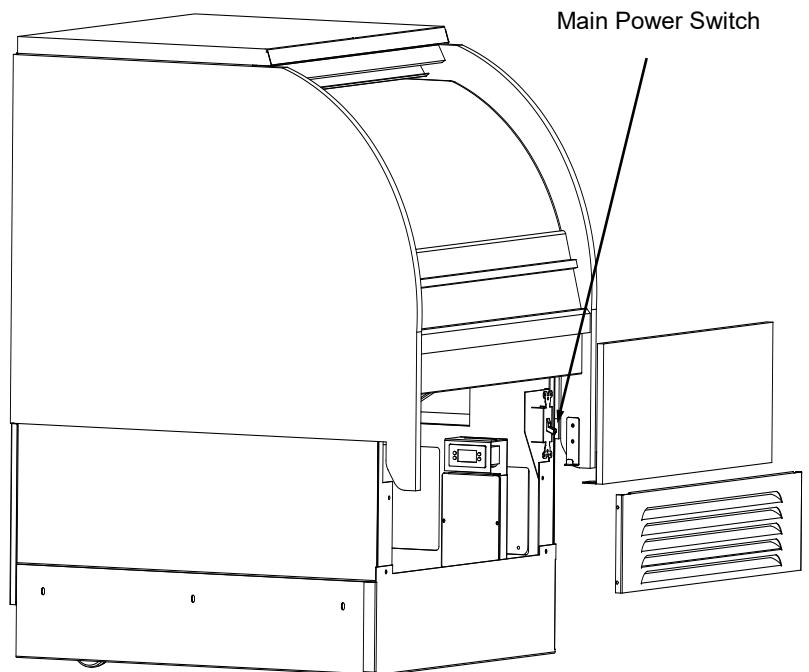
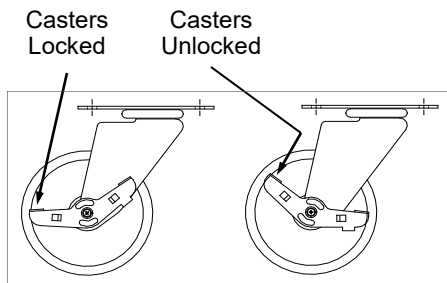

1. Removing the Front Panel

- Lifting the panel from lower edge upward approximately a half inch into a channel lip, disengages the support tabs on the lower edges.
- Pivot out lower edge approximately one inch and lower panel to remove.

2. Removing the Front Grille

- Lifting the grille upward approximately a half inch disengages a top support flange and the support tabs on the back lower side of the grille from the frame .
- Pivot out lower edge and remove grille.

3. Light Fixture

Removal of lamp:

- Rotate lamp (1/4 turn) either direction to disengage (upper or lower) pins/contacts from lamp mounting sockets.
- Remove bulb buy applying even pressure from the back side at the bulb ends and pulling the remaining contact from the sockets.

Installation of lamp:

- Align pins with slot.
- Insert pins into socket by rotating the bulb 1/4 turn to secure either the (upper or lower) pined contacts into the sockets.
- Rotate the remaining bulb contacts (1/4 turn) into the remaining lamp mounting socket contacts.

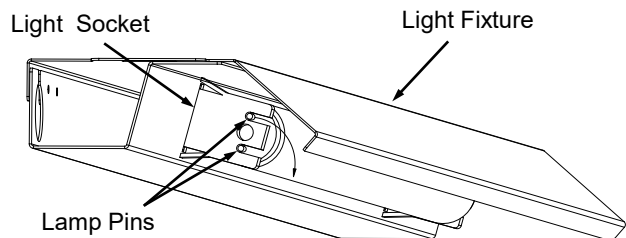
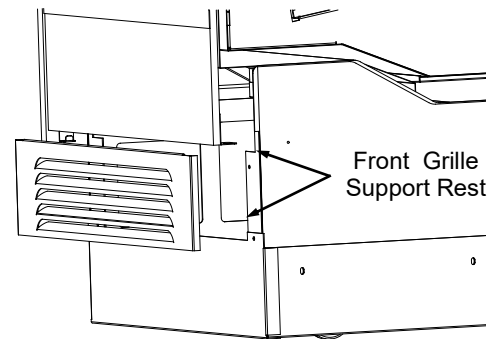
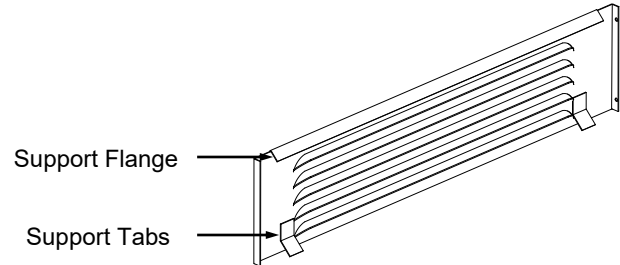
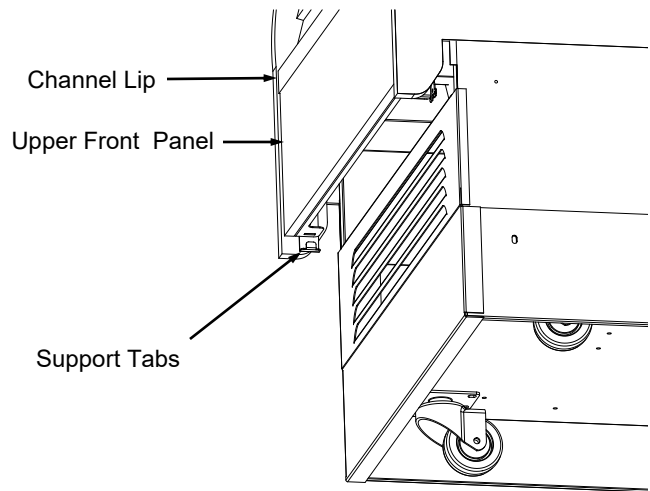

Preventive maintenance should be performed every 30 days unless conditions warrant a more frequent replacement cycle.

Honeycomb Air Diffuser Removal

Honeycomb is located in discharge air duct.

A. Wedge a non-metallic device of suitable strength (such as a ballpoint pen) between the honeycomb and the end panel.

Caution! Use care not to dislodge the heating wire (that prevents condensation on the lamp assembly).

B. Apply pressure to collapse the honeycomb to allow it to be pulled out of honeycomb retainer.

C. Pry downward and away from honeycomb retainer.

- Clean honeycomb with warm water and soap solution.
- Submerge if necessary.
- Use brush to dislodge stubborn or sticky residue.
- Dry by using vacuum's blow mode (vs. suction mode).

Honeycomb Air Diffuser Installation

D. Squeeze honeycomb to allow it to fit into honeycomb retainer.

E. Carefully slide honeycomb into place.

F. Adjust honeycomb so that it fits flat against retainer. It must not be wavy or out of position.

Note: For honeycomb air diffusers in other locations, these same general instructions apply.

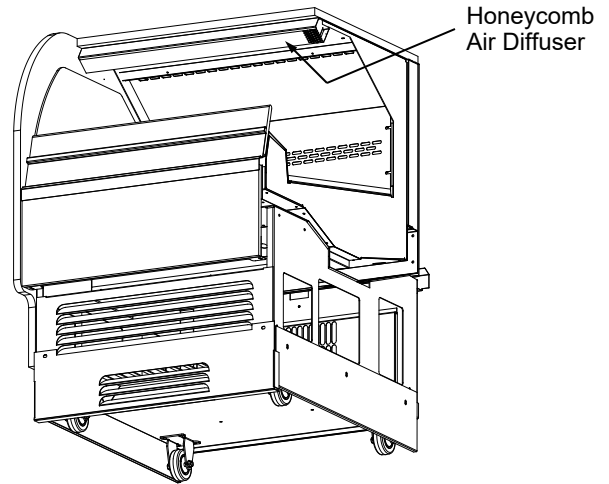

Note: Model features and options may vary.

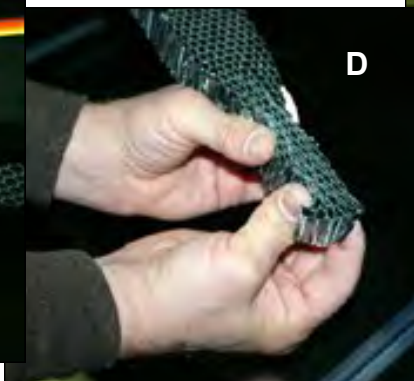
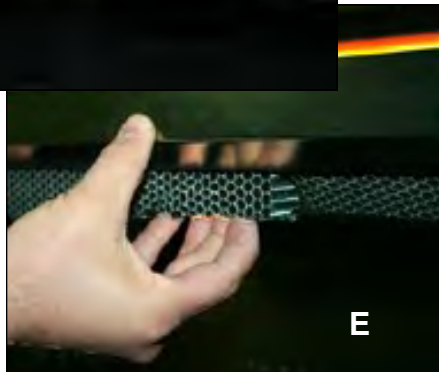

1. Electrical: Access and Connections

Warning, disconnect power before providing maintenance and service to unit.

2. Light Ballast Access

- Remove three screws from the rear wire channel.
- Remove four screws from the rear grille.

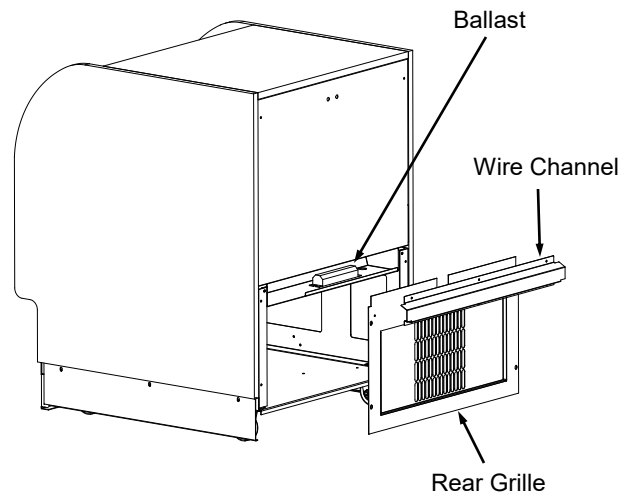

REFRIGERATION FUNDAMENTALS

1. Temperature & Defrost Control

- The case temperature is set at the factory, as determined by the case size. The temperature is controlled by a thermostat. If a temperature setting change is required, follow the instructions for the Temperature Control Programming Steps in the technical information section of this operating manual.
- If service is required to the temperature control unit, call Structural Concepts. This maintenance should be performed by a certified technician.

2. Evaporator Fan Access

- Remove lower decking. A finger hole is provided to assist in lifting up and pulling out deck.

3. Expansion Valve Access

- Remove lower decking. A finger hole is provided to assist in lifting up and pulling out deck.
- Remove fan shroud assembly.
 - Unplug the fan at the shroud support.
 - Remove four screw knobs from the fan shroud.
- Carefully remove shroud to avoid damage to mirrors or front air deflector.

4. Refrigeration:

Access and Connections

- **Assembly or disassembly and servicing to be accomplished by licensed refrigeration contractor.**
- Refer to maintenance fundamentals for access.
 - Remove front panel.
 - Remove front grille.

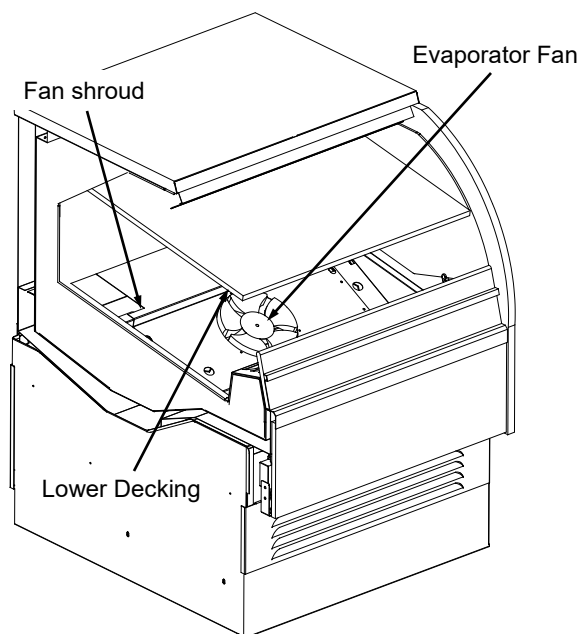
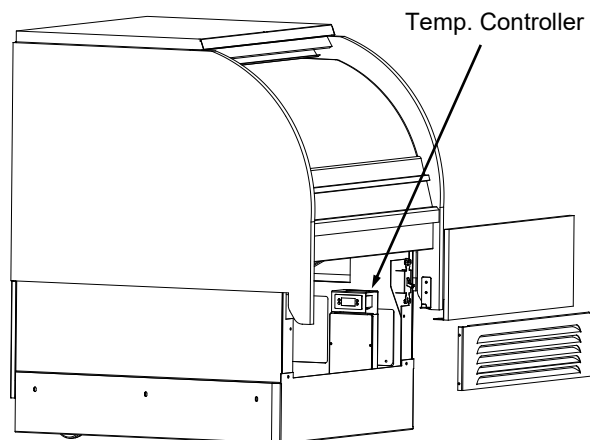

Hot Gas Evaporator

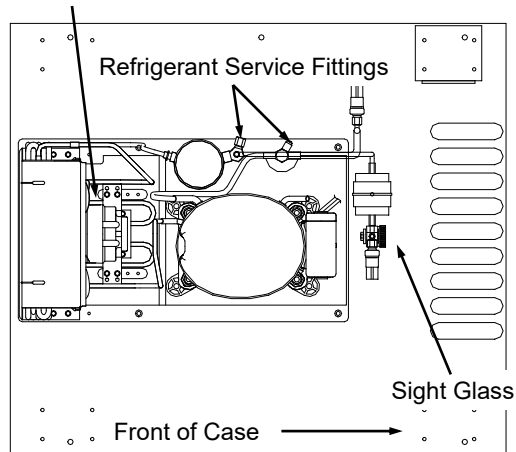

Serial Label Location & Information Listed / Technical Information & Service

- Serial labels are located near the electrical access on your case.
- Serial labels contain electrical, temperature & refrigeration information, as well as regulatory standards to which the case conforms.
- For additional technical information and service, see the *TECHNICAL SERVICE* page in this manual for instructions on contacting Structural Concepts' Technical Service Department.
- See images below for samples of both refrigerated and non-refrigerated serial labels.



888 E. Porter Rd · Muskegon, MI 49441

ENCORE[®] MODEL HV74RSS SCROLL
SERIES SERIAL NO.

FOR PARTS AND SERVICE
CALL 1-800-433-9489

SAMPLE ONLY



3048256
CONFORMS TO UL STD 471
CONFORMS TO NSF STD 7
CERTIFIED TO CAN/CSA
STD C22.2 NO 120

ELECTRICAL RATING	120/1/60 24A
REFRIGERANT	R404A AMOUNT ?? OZ
DESIGN PRESSURE	HIGH 450 LOW 200
MINIMUM CIRCUIT	30A
MAXIMUM OVERCURRENT	30A

SAMPLE ONLY

Super Heat Temp	8-10°F
BTUH Requirements	9,738 BTUH @ 20° F SST
Defrost	6 defrosts per day, 45° F termination, 45 min. failsafe

SAMPLE ONLY

----- Sample Serial Label For Refrigerated Case -----



888 E. Porter Rd · Muskegon, MI 49441

Addenda[®] PC5682 txtRemote
txtSerialNumber

120 VOLTS 60 HZ SINGLE PHASE 1.84AMP

FOR PARTS OR SERVICE CALL
STRUCTURAL CONCEPTS
AT
1-800-433-9489



3048256
CONFORMS TO UL STD 65
CERTIFIED TO CAN/CSA
STD C22.2 NO 120

SAMPLE ONLY

----- Sample Serial Label For Non-Refrigerated Case -----

TROUBLESHOOTING - GENERAL

Problem	Solution
Alarm Going Off	See alarm and fault codes of temperature controller.
Product is Drying Out	Check the relative humidity in the store.
Water on the Floor	Check the drain trap is free of debris.
	Check that the condenser hot gas evaporator for cleanliness.
Excessive Fan Noise	Check that the case is aligned, level and plumb.
	Check that nothing is obstructing the blade rotation.
	Check that the fan shroud is properly secured.
System is not Operating	Check that the utility power is on.
	Check that the MAIN power switch is on.
	Check the circuit breaker box for tripped circuits.
Temperature Controller Has No Illumination	Check connections on power supply contactor board.
	Check fuse on power supply contactor board.
Fans Not Working	Check that the power is on.
	Check that fans are plugged in at the fan shroud.
	Faulty motor.
Case Lights Not Working	Check bulbs for proper installation and connection.
	Check for burned out bulbs.
	Clean dirt and dust from the bulbs to prevent flickering.
	Faulty ballast.
Not Holding Temperature	If a large amount of warm product was added to the case, it will take time for the temperature to adjust.
	The temperature will change during defrost mode but will return to normal.
	Check that the case is not in the sun or near a heat or air-conditioning vent.
	Case may be located too near store's outside doors.

TROUBLESHOOTING - CONDENSING SYSTEM (BY TRAINED SERVICE PROVIDERS ONLY)

CONDITION	TROUBLESHOOTING
Head Pressure Too High	Check that the condensing coil is not dirty or covered.
	Check that condensing fans are working.
	Check that refrigerant is not overcharged.
	Perform sub-cooling check and verify that no contaminants are in system.
	Check that liquid line filter dryer is not plugged.
	Check that close-offs are intact (around condensing coil) and that air is not recirculate.
	Check that store ambient temperature isn't above maximum allowed. See OVERVIEW / TYPE / COMPLIANCE / WARNINGS / PRECAUTIONS / WIRING / PLUGS section in this manual.
Head Pressure Too Low	Check if sight glass is flashing or showing low charge.
	Check that suction pressure isn't too low.
	Check that compressor reed valves aren't bad. Look for high suction/low head pressure. Perform pump-down.

TROUBLESHOOTING - EVAPORATOR SYSTEM (BY TRAINED SERVICE PROVIDERS ONLY)

CONDITION	TROUBLESHOOTING
Low Suction Pressure	Check if sight glass is flashing or showing low charge.
	Check that expansion valve (TXV) isn't restricted. Check element charge.
	Check that liquid line or filter isn't restricted. Check that refrigeration lines and/or hoses are not kinked on either high or low sides.
	Check that evaporator fan motors are working.
	Check that superheat is between 6 °F to 8 °F.
	Check that there is no air recirculation around evaporator coil.
	Check that evaporator coil is not iced up.
High Suction Pressure	Check for refrigerant overcharge.
	Check that compressor reed valves aren't bad. Look for high suction/low head pressure. Perform pump down.
	Check that the "cooling load" isn't high. Product must be pre-chilled before placing in refrigerated section of case.
	Check that case is at least <u>15-feet</u> from exterior doors, overhead HVAC vents or any air curtain disruption.
	Check that unit is not exposed to direct sunlight via windows or any other heat source (ovens, fryers, etc.).
	Check that superheat adjustment isn't low.
	Check TXV bulb installation <ul style="list-style-type: none"> a. Poor thermal contact. b. Warm location.

ILLUSTRATED PARTS BREAKDOWN

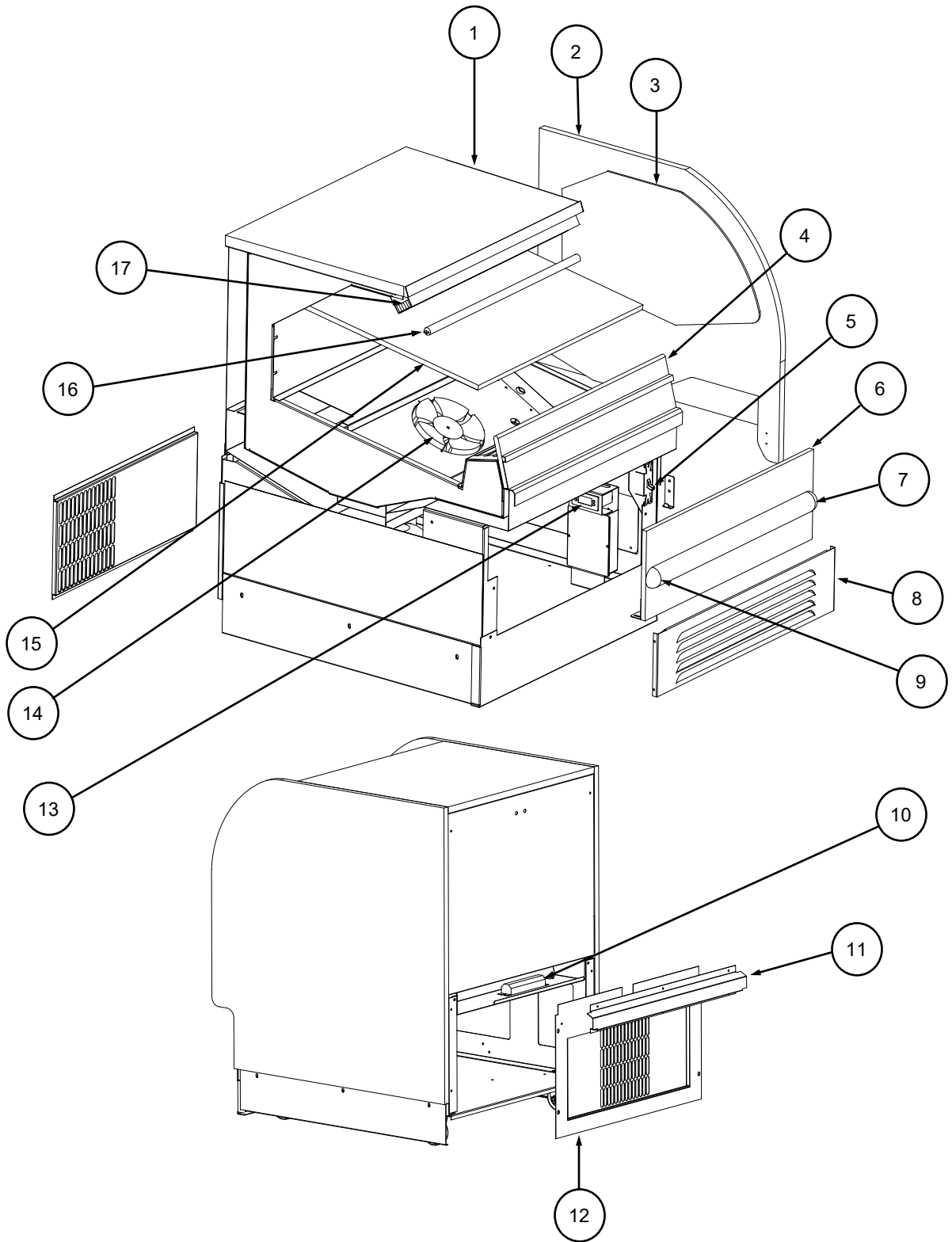

PARTS LIST

1	Top Board	10	Light Ballast
2	End Panel	11	Wire Channel
3	End Panel Mirror	12	Rear Grille
4	Air Deflector Glass	13	Temperature Controller
5	Single Pole Switch	14	Fan Motor, Evaporator
6	Front Panel	15	Deck Pan
7	Bumper Insert	16	Lamp Bulb
8	Front Grille	17	Honeycomb
9	Bumper End Cap		

CLEANING SCHEDULE

Cleaning	Daily	Weekly	Monthly	Task
Clean Case Exterior	X			The acrylic must be cleaned with a mild soap and water solution and a soft cloth. Never use a household cleaner on acrylic.
Clean Case Interior	X			Clean glass shelves and mirrors with a household or commercial glass cleaner. The deck can be cleaned with a warm soap and water solution.
		X		Remove the deck and clean with soap and water.
		X		Remove rear doors and clean with a household or commercial cleaner.
		X		Vacuum tub under deck or soap and water if necessary. To flush out the tub, disconnect power to the case. Remove the ABS deck and the fan shroud. Note: Be sure to plug fans back in after cleaning and before installing decks.
		X		Keep drain clean and free of debris which could clog the drain and rob the case of needed refrigeration.
Clean Condensing Coil		X		Vacuum grille area on back of case.
			X	Using air pressure if available, or an industrial strength vacuum, clean the dust and dirt that collects on the condenser coil.

CAREL

ir33 platform
Integrated Electronic
Microprocessor Controller



Programming The Instrument

To Modify The Setpoint

Set Press and hold the "SET" key for at least 1 second.

▲ **def** 2. Use arrow keys ▲ ▼ on temperature
aux ▼ controller to increase (or decrease) the
setpoint.

Set 3. Quickly press and release the "SET" key again.

To Modify Defrost, Differential or Other Parameters

Prg **Set** 1. Press & hold "Prg" & "SET" keys together
mute for five (5) seconds; display will flash "0",
representing password prompt.

Set 2. Confirm by pressing "SET" key.

▲ **def** 3. Press ▲ or ▼ to reach the
aux ▼ category to be modified.

Set 4. Press "SET" to modify this selected parameter.

▲ **def** 5. Increase or decrease the value using
aux ▼ the ▲ or ▼ button respectively.

Set 6. Press the "SET" key to temporarily save the new
value and return to the display of the parameter.

Prg 7. Press & hold the "Prg" key for at least 5 seconds
mute to save changes. This action will also mute the
audible alarm (buzzer) & deactivate the alarm relay.

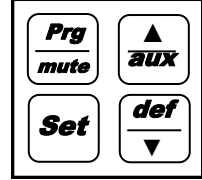

How To Change Reading From Fahrenheit (°F) To Celsius (°C)

Prg **Set** 1. Press and hold "Prg" and "SET" keys
mute together for at least 5 seconds; display will
show "0", representing password prompt.

Set 2. Confirm by pressing "SET" key.

▲ **def** 3. Press ▲ or ▼ until reaching the
aux ▼ parameter "/ 5".

Set 4. Press "SET" to modify this selected parameter.

▲ **def** 5. Press ▲ or ▼ to change value to desired
aux ▼ setting: "0" for Celsius (°C) or "1" for
Fahrenheit (°F).

Set 6. Press "SET" key to temporarily save the new
value and return to the display of the parameter.

Prg 7. Press & hold "Prg" key for at least 5 seconds to
mute save changes. **Note! All values will automatically
convert to new scale. No conversion is required.**

Warning! Save Your Parameter Settings!

1. To store the new parameter values, PRESS and HOLD the "Prg" key for at least 5 seconds.
2. All modifications made to parameters will be lost if you do NOT press a button within 60 seconds. Should this "timeout" occur, normal operational settings (prior to modifications being made) will resume.
3. If the instrument is switched off before pressing the "Prg" key, all modifications to parameters will be lost.

def **To Activate Manual Defrost**
▼ Press and hold the "def" key for at least 5 seconds.

▲ **To Activate / Deactivate Auxiliary Output**
aux Press and hold the "aux" key for 1 second.

Prg **To Reset Any Alarms With Manual**
mute **▲** **Reset**
aux Press and hold the "Prg" and "aux"
key for at least 1 second.

CAREL

ir33 platform
**Integrated Electronic
 Microprocessor Controller**



User Interface - Display

ICON	FUNCTION	DESCRIPTION	Normal operation			Start up
			ON	OFF	BLINK	
	COMPRESSOR	ON when the compressor starts. Flashes when the activation of the compressor is delayed by safety times.	Compressor on	Compressor off	awaiting activation	
	FAN	ON when the fan starts. Flashes when the activation of the fan is prevented due to external disabling or procedures in progress.	Fan on	Fan off	awaiting activation	
	DEFROST	ON when the defrost is activated. Flashes when the activation of the defrost is prevented due to external disabling or procedures in progress.	Defrost in progress	Defrost not in progress	awaiting activation	
	AUX	Flashes if the anti-sweat heater function is active, ON when the auxiliary output (1 and/or 2) selected as AUX (or LIGHT in firmware version 3.6) is activated.	AUX auxiliary output active (version 3.6 light auxiliary output active)	AUX auxiliary output not active	Anti-sweat heater function active	
	ALARM	ON following pre-activation of the delayed external digital input alarm. Flashes in the event of alarms during normal operation (e.g. high/low temperature) or in the event of alarms from an immediate or delayed external digital input.	Delayed external alarm (before the time 'A7' elapses)	No alarm present	Alarms in norm. operation (e.g. High/low temperature) or immediate or delayed alarm from external digital input	
	CLOCK	ON if at least one timed defrost has been set. At start-up, comes ON for a few seconds to indicate that the Real Time Clock is fitted.	If at least 1 timed defrost event has been set	No timed defrost event set	Alarm clock	ON if real-time clock present
	LIGHT	Flashes if the anti-sweat heater function is active, ON when the auxiliary output (1 and/or 2) selected as LIGHT is activated (in firmware version 3.6 it does not flash in anti-sweat heater mode and comes on when the dead band output is active).	Light auxiliary output on (version 3.6 dead band auxiliary output active)	Light auxiliary output off	Anti-sweat heater function active (version 3.6 does not flash in anti-sweat heater mode)	
	SERVICE	Flashes in the event of malfunctions, for example E2PROM errors or probe faults.		No malfunction	Malfunction (e.g. E2PROM error or probe fault). Contact service	
	CONTINUOUS CYCLE	ON when the CONTINUOUS CYCLE function is activated. Flashes if the activation of the function is prevented due to external disabling or procedures in progress (E.g.: minimum compressor OFF time).	CONTINUOUS CYCLE operation activated	CONTINUOUS CYCLE function not activated	CONTINUOUS CYCLE operation requested	

Summary Table of Alarm and Signals: Display, Buzzer and Relay

Code	Icon on the display	Alarm relay	Buzzer	Reset	Description
rE	flashing	on	on	automatic	virtual control probe fault
E0	flashing	off	off	automatic	room probe S1 fault
E1	flashing	off	off	automatic	defrost probe S2 fault
E2	flashing	off	off	automatic	probe S3 fault
E3	flashing	off	off	automatic	probe S4 fault
E4	flashing	off	off	automatic	probe S5 fault
'	No	off	off	automatic	probe not enabled
LO	flashing	on	on	automatic	low temperature alarm
HI	flashing	on	on	automatic	high temperature alarm
AFr	flashing	on	on	manual	antifreeze alarm
IA	flashing	on	on	automatic	immediate alarm from external contact
dA	flashing	on	on	automatic	delayed alarm from external contact
dEF	on	off	off	automatic	defrost running
Ed1	No	off	off	automatic/manual	defrost on evaporator 1 ended by timeout
Ed2	No	off	off	automatic/manual	defrost on evaporator 2 ended by timeout
Pd	flashing	on	on	automatic/manual	maximum pump down time alarm
LP	flashing	on	on	automatic/manual	low pressure alarm
AtS	flashing	on	on	automatic/manual	autostart in pump down
cht	No	off	off	automatic/manual	high condenser temperature pre-alarm
CHT	flashing	on	on	manual	high condenser temperature alarm
dor	flashing	on	on	automatic	door open too long alarm
EE	flashing	off	off	automatic	E2prom error, unit parameters
EF	flashing	off	off	automatic	E2prom error, operating parameters
ccb	Signal				start continuous cycle request
ccE	Signal				end continuous cycle request
dFb	Signal				start defrost call
dFE	Signal				end defrost call
On	Signal				switch ON
off	Signal				switch OFF
rES	Signal				reset alarms w/manual reset / reset HACCP alarms / reset temp. monitoring

CAREL

ir33 platform
 Integrated Electronic
 Microprocessor Controller



Summary Table of Operating Parameters

CODE	PARAMETER	UOM*	TYPE	MINIMUM	MAXIMUM	DEFAULT
/5	Select Celcius (°C) or Fahrenheit (°F)	flag	C	0	1	For Case Specific Defaults See Serial Label Located Near Electrical Access On Your Case. For Additional Technical Information Call Structural Concepts Technical Service Dept. at 1(800) 433.9489
/c1	Calibration of probe 1	°C/°F	C	-20	20	
/c2	Calibration of probe 2	°C/°F	C	-20	20	
St	Temperature set point	°C/°F	F	r2	r1	
rd	Control delta	°C/°F	F	20	0.1	
dl	Interval between defrosts	hours	F	0	250	
dt1	End defrost temperature, evaporator	°C/°F	F	-50	200	
dP1	Maximum defrost duration, evaporator	min	F	1	250	
d6	Display on hold during defrost	-	C	0	2	
dd	Dripping time after defrost	min	F	0	15	
d/1	Display of defrost probe 1	°C/°F	F	-	-	

* Unit Of Measure

Alarm and Fault Codes

These alarm and fault codes will flash on the display when the control detects the following faults:

Table 1: Error Codes and Status

Error Code	System Status
F1 Indicates an open or shorted temperature sensor	Alarm output is on. Compressor runs according to the sensor failure mode selected (parameter SF). Cycle power to reset control.
F2 Indicates an open or shorted evaporator sensor	Alarm output is on. Defrost cycle is controlled by parameters di (defrost initiation) and dd (defrost duration). Correct problem to reset control.
A1 Indicates that the digital input was open for longer than the time delay (id) and digital input (iF) Option 1 is selected	Compressor output is off. Alarm output is on. Correct problem to reset control.
A2 Digital input closed for longer than time delay (id) and digital input (iF) Option 2 is selected	Alarm output is on. Correct problem to reset control.
A3 Digital input open for longer than the time delay (id) and digital input (iF) Option 3 selected	Fan output is off. Alarm output is on. Correct problem to reset control.
HI Temperature has exceeded the high temperature alarm value (AH)	Alarm output is on. Correct problem to reset control.
LO Temperature has fallen below the low temperature alarm value (AL)	Alarm output is on. Correct problem to reset control.
EE Program failure	Alarm output is on. Other outputs are off. Replace control.

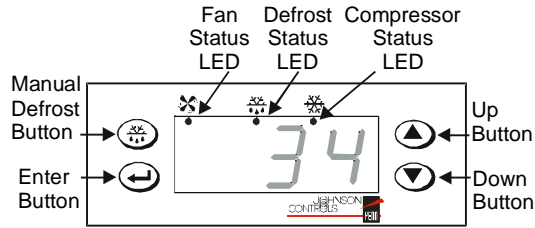

To Lock and Unlock The Unit for Programming

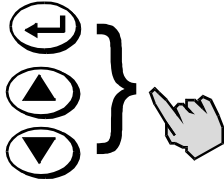

Press the Enter, Up, and Down buttons in sequence and hold them all down until “- -” is displayed. Hold for about 10 seconds until the current temperature is displayed. This toggles the keypad between locked and unlocked.

To change the set point

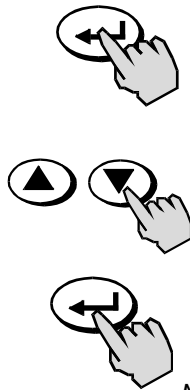

1. Hold the Enter button down for 3 seconds. The display will change to show the set point. Release the Enter button.
2. Press the Up or Down button until you reach the new set point.
3. Press the Enter button to save the new set-point.

Note: If the Enter button is not pressed after selecting the new set point, the new set point is not saved, and the control will revert to the original set point.

To Begin a Manual Defrost Cycle



Hold the Defrost button down for 3 seconds.

To Begin a Deep Freeze Cycle

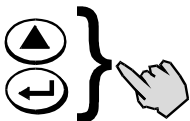

Press the Enter and Up buttons in sequence and hold both for 5 seconds. The compressor status LED will light.

To Program Values Other Than The Setpoint

A parameter settings reference page is included in Table 3 of this bulletin. Filling out the parameter settings before programming may be helpful.

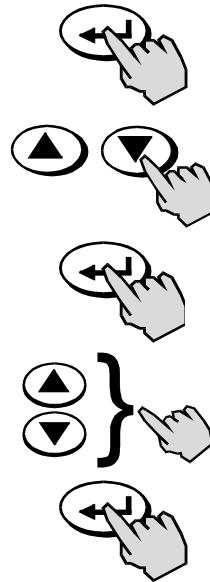

1. Hold the Enter button down for about 10 seconds. The display will change to HY.
2. Press the Up or Down button until the desired parameter is displayed.
3. Press the Enter button. The parameter's current value is displayed.
4. Press the Up or Down button until the desired value is shown.
5. Press the Enter button to save the new value. After 10 seconds of inactivity, the display will return to its normal function.

Note: If the Enter button is not pressed after selecting the new value, the new value is not saved, and the control will revert to using the previous value.

To Run the Self-Test Procedure

Press the Up and Down buttons in sequence, and hold for 5 seconds.

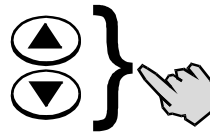

IM-loads procedure. Cycle power to resume normal operation. **PORTANT:** Disconnect before beginning Self-test operation.

STRUCTURAL CONCEPTS TECHNICAL SERVICE CONTACT INFORMATION & LIMITED WARRANTY

TECH SERVICE/WARRANTY CONTACT INFO: 1 (800) 433-9490 / EXTENSION 1

DAYS/HOURS AVAILABLE:
MONDAY - FRIDAY (CLOSED HOLIDAYS)
8:00 a.m. TO 5:00 p.m. EST

YOU MUST HAVE THE FOLLOWING INFO AVAILABLE BEFORE CONTACTING STRUCTURAL CONCEPTS:

SERIAL NO. / MODEL NO. / STORE NO. / STORE
ADDRESS / DETAILS (PHOTOS, LEAK LOCATIONS,
DAMAGE, STORE'S AMBIENT CONDITIONS, ETC.)

LIMITED WARRANTY

Overview: All sales by Structural Concepts Corporation (hereafter referred to as "SCC") are subject to the following limited warranty. "Goods" refers to the product or products being sold by SCC.

Warranty Scope: Warranty is for equipment sold in the United States, Canada, Mexico and Puerto Rico. Equipment sold elsewhere may carry modified warranties.

Warranty; Remedies; Limitations: The limit of liability of SCC toward the exchange cost of the original compressor motor (and/or any other components) is one year parts and labor. If any Goods are found to be of faulty material or workmanship within one year of the original F.O.B. (free on board) unit shipment, SCC will, at its option (after inspection by an authorized representative), replace or pay the reasonable cost of replacement of the faulty Goods. If warranty claim is not made within this one year time period, SCC is not bound to warrant Goods. A motor-compressor (and/or any other components) replaced during the warranty shall not exceed manufacturer's current established wholesaler's exchange price. If replacement motor-compressor (and/or other components) is available via storage facility, parts truck, etc., SCC mandates that readily accessible replacement components be used toward repair of Goods; in such instances, SCC will replace such equipment (at its own expense) after confirmation of its use/placement on defective unit. SCC shall not be charged an additional fee, up-charge or expense for such replacement Goods. If SCC is unable to repair or replace the defective Goods, SCC shall issue a credit to the Purchaser for full or partial purchase price, as SCC shall determine. The replacement or payment in the manner described above shall be the sole and exclusive remedy to Purchaser for a breach of this warranty. If any Goods are defective or fail to conform to this warranty, SCC will furnish instructions for their disposition. No Goods shall be returned to SCC without its prior consent.

SCC's liability for any defect in the Goods shall not exceed the purchase price of the Goods. SCC SHALL HAVE NO LIABILITY TO PURCHASER FOR CONSEQUENTIAL DAMAGES OF ANY KIND WHATSOEVER, INCLUDING, BUT NOT LIMITED TO, PERSONAL INJURY, PROPERTY DAMAGE, LOST PROFITS, OR OTHER ECONOMIC INJURY DUE TO ANY DEFECT IN THE GOODS OR ANY BREACH OF SCC, SCC SHALL NOT BE LIABLE TO THE PURCHASER IN TORT FOR ANY NEGLIGENT DESIGN OR MANUFACTURE OF THE GOODS, OR FOR THE OMISSION OF ANY WARNING THEREFROM.

SCC shall have no obligation or liability under this warranty for claims arising from any other party's (including Purchaser's) negligence or misuse of the Goods or environmental conditions. This warranty does not apply to any claim or damage arising from or caused by improper storage, handling, installation, maintenance, or from fire, flood, accidents, structural defects, building settlement or movement, acts of God, or other causes beyond SCC's control.

Except as expressly stated herein, SCC makes no warranty, express, implied, statutory or otherwise as to any parts or goods not manufactured by SCC. SCC shall warrant such parts or Goods only (I) against such defects, (II) for such periods of time, and (III) with such remedies, as are expressly warranted by the manufacturer of such parts of Goods. Notwithstanding the foregoing, any warranty with respect to such parts of Goods and any remedies available as a result of a breach thereof shall be subject to all of the procedures, limitations, and exclusions set forth herein.

THE WARRANTIES HEREIN ARE IN LIEU OF ALL WARRANTIES, EXPRESS, IMPLIED, STATUTORY, OR OTHERWISE. IN PARTICULAR, SCC MAKES NO WARRANTY OF MERCHANTABILITY OR FITNESS FOR A PARTICULAR PURPOSE.

No representative, agent or dealer of SCC has authority to modify, expand, or extend this Warranty, to waive any of the limitations or exclusions, or to make any different or additional warranties with respect to Goods.

Period of Limitations: No claim, suit or other proceeding may be brought by Purchaser for any breach of the foregoing warranty or this Agreement by SCC or in any way arising out of this Agreement or relating to the Goods after one year from the date of the breach. In the interpretation of this limitation on action for a breach by SCC, it is expressly agreed that there are no warranties of future performance of the goods that would extend that period of limitation herein contained for bringing an action.

Indemnifications: Purchaser agrees to indemnify, hold harmless, and defend SCC if so requested, from any and all liabilities, as defined herein, suffered, or incurred by SCC as a result of, or in connection with, any act, omission, or use of the Goods by Purchaser, its employees or customers, or any breach of this Agreement by Purchaser. Liabilities shall include all costs, claims, damages, judgments, and expenses (including reasonable attorney fees and costs).

Remedies of SCC: SCC's rights and remedies shall be cumulative and may be exercised from time to time. In a proceeding or action relating to the breach of this Agreement by Purchaser, Purchaser shall reimburse SCC for reasonable costs and attorney's fees incurred by SCC. No waiver by SCC of any breach of Purchaser shall be effective unless in writing nor operate as a waiver of any other breach of the same term thereafter. SCC shall not lose any right because it has not exercised it in the past.

Applicable Law. This Agreement is made in Michigan; it is governed by and interpreted according to Michigan law. Any lawsuit arising out of this Agreement or the Goods may be handled by a federal or state court whose district includes Muskegon County, Michigan, and Purchaser consents that such court shall have personal jurisdiction over Purchaser.

LED Lighting Components Within Lighting System: Supermarket: 5-year LED warranty from date of shipment. **Foodservice:** 2-year LED warranty from date of shipment. After one year, warranty does not include labor or other costs incurred for diagnosing, repairing, removing, installing, shipping, servicing, or handling of either defective part or replacement parts. Remedy of repair or provision of a replacement part without charge shall be the exclusive remedy for any warranty claim. The replacement LED and/or power supply assumes the unused portion of warranty remaining on unit(s). A 90-day warranty will apply for any LED sold as a service part. Warranty claim must include serial and model number of unit as well as date code on defective LED lighting component(s). Manufacturer may request return of defective part(s) at customer's expense to initiate claim.

Glass Material: Glass (UV-bonded glass, glass sneeze guards, glass enclosures, glass held in place via posts, etc.) is only warranted to FIRST POINT OF DELIVERY.

Miscellaneous: If any provision of this Agreement is found to be invalid or unenforceable under any law, the provision shall be ineffective to that extent and for the duration of the illegality, but the remaining provisions shall be unaffected. Purchaser shall not assign any of its rights nor delegate any of these obligations under this Agreement without prior written consent of SCC. This Agreement shall be binding upon and inure to the benefit of SCC and Purchaser and each of their legal representatives, successors and assignees. SCC warrants its products to be free of defects in materials and workmanship under normal use and service for a period of one (1) year from the date of delivery.

This warranty is extended only to the original purchaser for use of the Goods. It does not cover normal wear parts such as plastic tongs, tong holders, tong cables, bag holders, or acrylic dividers.

General Conditions: All service labor and/or parts charges are subject to approval by SCC. Contact Customer Service Dept. in writing, by phone, fax or email.

All claims must contain the following information: (1) model & serial code number of equipment; (2) the date and place of installation; (3) the name and address of the agency which performed the installation; (4) the date of the equipment failure; and (5) a complete description of the equipment failure and all circumstances relating to that failure.

Once the claim has been determined to be a true warranty claim by SCC's Customer Service Department, the following procedure will be taken: (1) replacement parts will be sent at no charge from SCC on a freight prepaid basis; (2) reimbursement for service labor will be paid if the following conditions have been met - (a) prior approval of service agency was awarded from the Customer Service Department; and (b) an itemized statement of all labor charges incurred is received by the Customer Service Department. The cost of the service labor reimbursement will be based on straight time rates and reasonable time for the repair of the defect.

If problems occur with any compressor, notify SCC's Customer Service Department immediately. Any attempt to repair or alter the unit without prior consent from the Customer Service Department will render any warranty claim null and void. This warranty and protection plan does not apply to any condensing unit or any part thereof which has been subject to accident, negligence, misuse, or abuse, or which has not been operated in accordance with the manufacturer's recommendations or if the serial number of the unit has been altered, defaced, or removed.

One Year Limit of Liability: After SCC's one-year parts and labor warranty on the original F.O.B. (free on board) unit has expired, SCC is not liable for either the equipment or labor costs of repairing or replacing the motor compressor, nor any other components that were included in the original F.O.B. (free on board) unit.