



Project _____
 AIA # _____ SIS # _____
 Item # _____ Quantity _____ C.S.I. Section 114000



DEALERS CHOICE PREP TABLES - R290

UST SERIES - R290

Compact Sandwich Prep Tables with Flat Cover/Self-Contained

UST 60" Wide Models



STANDARD PRODUCT FEATURES

- High Quality Stainless Steel Exterior Top, Sides & Door(s)
- Durable, Corrosion Resistant Anodized Aluminum Interior
- Provides NSF Standard 7 Performance, Even When Using 6" Deep Pans
- Standard Work Height 34-3/8" on 4" casters
- Environmentally Friendly R-290 Refrigerant
- Top Cut-Outs Accommodate Sixth Size Pans (divider bars and 4" deep plastic sixth size pans provided)
- Reinforced Pan Ledge (holds pans securely level)
- Reversible, Full Length White Nylon Cutting Board
- Self-Closing Stainless Steel Doors with Convenient Stay Open Feature at 105 Degrees
- Guaranteed for Life Workflow Handles
- Electronic Control
- Two (2) Powder Coated Steel Shelves Per Door, Mounted on Adjustable Pilasters
- Set of Six (6) 4" Casters
- Magnetic Snap-In EZ-Clean Door Gasket(s)
- 3-Year Parts And Labor Warranty
- 2-Years Additional Compressor Parts Warranty



This unit is listed to the applicable UL, CSA and NSF Standards by an approved NRTL. Consult the factory or unit's data plate for approval information.

AVAILABLE CONFIGURATIONS

27", 32", 48", 60" & 72" Wide Models

Model	Model Type	Hinging
UST6012LR-0300	60" Wide 8 Pan Model	Left/Right
UST6012LL-0300	60" Wide 8 Pan Model	Left/Left
UST6012RR-0300	60" Wide 8 Pan Model	Right/Right
UST6024LR-0300	60" Wide 12 Pan Model	Left/Right
UST6024LL-0300	60" Wide 12 Pan Model	Left/Left
UST6024RR-0300	60" Wide 12 Pan Model	Right/Right

ACCESSORIES & OPTIONS (*field installed)

- CK21 (six 6" (15.2 cm) high casters for 60" models)
- CK25 (six 3-1/2" (8.9 cm) high casters for 60" models)
- CK27 (six 2-3/4" (6.9 cm) high casters for 60" models)
- LK6 (six 6" (15.24 cm) high legs for 60" models)
- SHELF60 UPPER (upper shelf for 60" models)
- SHELF60 LOWER (lower shelf for 60" models)
- Optional accessory kits shipped separately for field installation

FACTORY INSTALLED OPTIONS

Stainless Steel Finished Back * Other Door Hinging

Approved by _____ Date _____ Approved by _____ Date _____



MODELS:
UST6012LR-0300

CLICK
TRANSFER
For KCL CADalog Website

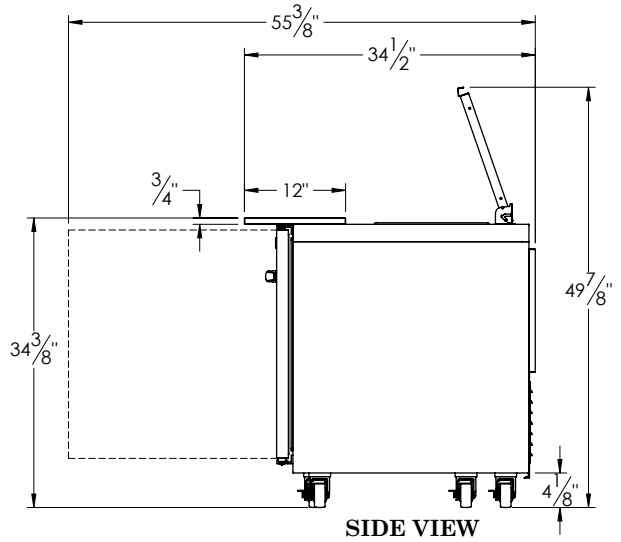
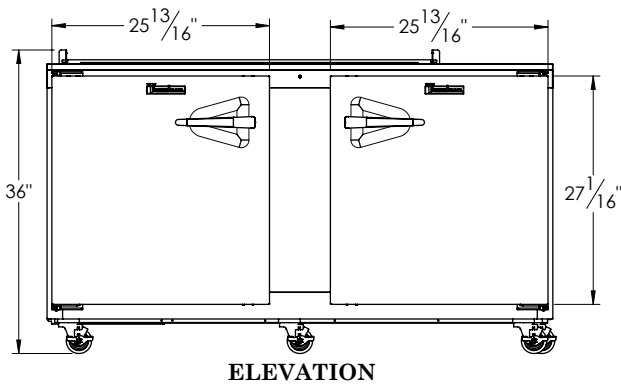
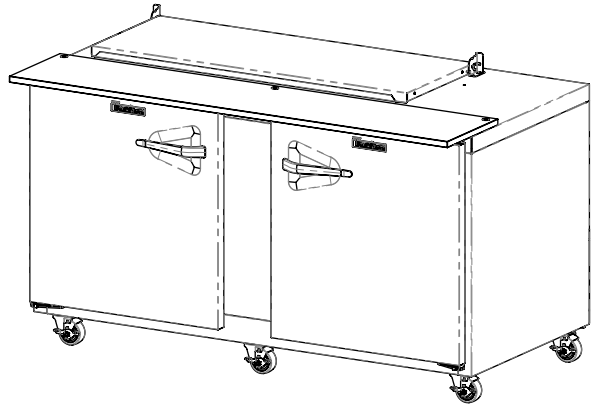
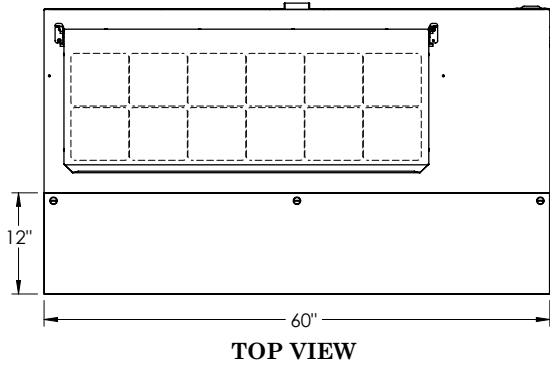

UST SERIES - R290

Compact Sandwich Prep Table

MODELS:

UST6024LR-0300

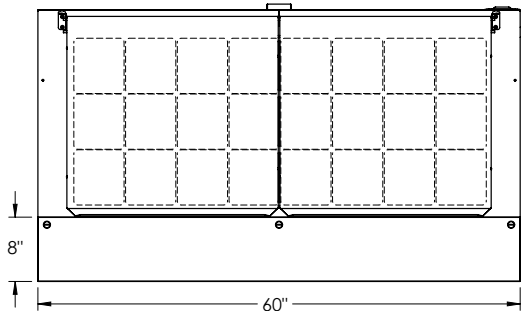

TOP VIEW

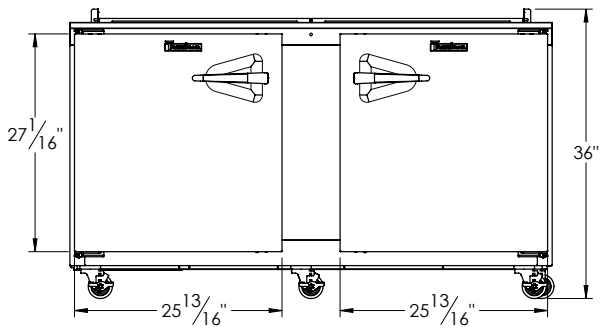
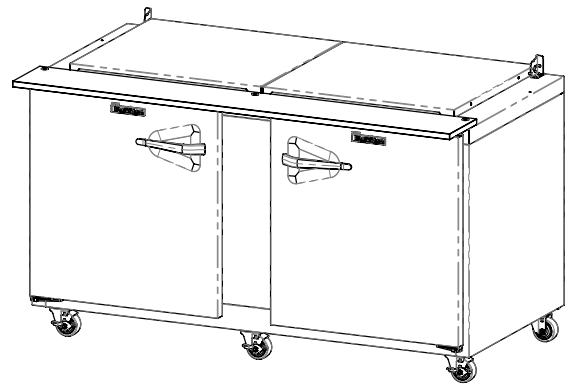

ELEVATION

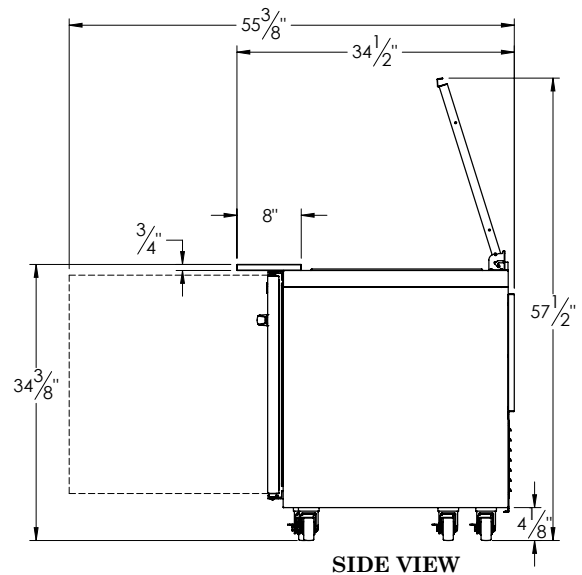

SIDE VIEW



UST SERIES - R290

Compact Sandwich Prep Tables Self-Contained

MODELS

Door Models: UST6012LR-0300, UST6012LL-0300,
UST6012RR-0300, UST6024LR-0300, UST6024LL-0300,
UST6024RR-0300

MODELS	UST6012__-0300 UST6024__-0300
CABINET DIMENSIONAL DATA	
Volume	N/A
# of 1/6 Size Pan Top	12 24
Width- Cabinet	60"
Width-Door	25 7/8"
Depth-door open 90°	55 3/8"
Depth-Cutting Board	12" 8"
Height -Lid Open at 70°	16 1/4" 23 3/4"
Clear Door Opening	22 3/4"
# of Doors	2
# of Shelves	4
Total Shelf area sq. ft	13.2
ELECTRICAL DATA & REFRIGERATION DATA 115/60/1 NEMA 5-15P	
Full Load Amps	7.2
MDEC ¹	N/A
Refrigerant	R-290
Refrigerant Amt oz. (gr)	5 (142)
BTU/HR H.P. ²	1680 1/5
SHIPPING DATA	
Width Crated in. (cm)	69 (175)
Volume Crated cu. ft. (l)	69 (1954)
Weight lbs. (kg) - Crated	368 (167)

EQUIPMENT SPECIFICATIONS

CONSTRUCTION, HARDWARE, INSULATION

Cabinet exterior front, sides, pan cover lid and doors are constructed of 22 gauge stainless steel. Cabinet interior and door liners are constructed of anodized aluminum. The exterior cabinet back at the bottom are constructed of galvanized steel.

Doors self close at less than 90 degrees and also includes a stay open feature at 105 degrees. Gasket profile and material simplify cleaning and increase overall gasket life.

Both the cabinet and doors are insulated with an average of 2" thick high density non-CFC, foamed in place polyurethane. A 3/4" thick, full-length, reversible white nylon cutting board is supplied standard.

PANS & COVER

Each model is supplied standard with its full compliment of 4" deep plastic 1/6 size pans and stainless steel pan dividers. The lid is constructed of stainless steel, and is easily removable for cleaning.

REFRIGERATION SYSTEM

A balanced, rear mounted, front breathing, self-contained refrigeration system using environmentally friendly R-290 refrigerant is provided. It features a capillary tube metering device, air cooled hermetic compressor, a forced air evaporator coil and a non-electric condensate evaporator. An 8' cord and plug is provided. Standard operating temperature of the refrigerated base is 34° to 38°F (1.1° to 3.3°C).

CONTROLLER

An electronic digital control is supplied standard. It includes a 3-Digit LED display, and a Fahrenheit or Celsius temperature scale display capability.

INTERIOR

Standard interior arrangements include two (2) powder coated wire shelves per door, mounted on pilasters. These are adjustable in 1/2" (1.27 cm) increments, allowing for a minimum of 1-1/2" (3.81 cm) spacing between shelves.

WARRANTIES

Both a three year parts and labor warranty and a five year compressor parts warranty (self-contained models only) are provided standard.

NOTES:

- MDEC = Maximum Daily Energy Consumption
 - Compressor BTU based on a 90°F ambient and 20°F evaporator
- When ordering please specify: Voltage, Hinging, Optional Accessories and any additional warranties.
 - This unit may be manufactured in other electrical characteristics and may have additional regulatory agency approvals. Consult factory for other electrical characteristics and agency approvals based on specific electrical and country requirements. (For exact electrical information and approval marks, always refer to the data label of the unit.)

CONTINUED PRODUCT DEVELOPMENT MAY NECESSITATE SPECIFICATION CHANGES WITHOUT NOTICE.