

Operator's Manual

COUNTERTOP DEEP FRYER



Model	Description	Voltage	HZ	kW	Plug
40705	10 lb. Countertop Fryer	120V	50/60	1.8 (15 Amps)*	5-15P
40706	10 lb. Countertop Fryer	220V	50/60	2.5 (11.3 Amps)*	6-15P
40707	20 lb. Countertop Fryer	120V	50/60	2 x 1.8 (2 x 15 Amps)**	2 x 5-15P
40708	20 lb. Countertop Fryer	220V	50/60	2 x 2.5 (2 x 11.3 Amps)**	2 x 6-15P

*One (1) dedicated 20 Amp circuit with a single outlet is required for each fryer head.

**Two separate dedicated 20 Amp circuits with a single outlet for each fryer head is required.

Thank you for purchasing this Vollrath equipment. Before operating the equipment, read and familiarize yourself with the following operating and safety instructions. **SAVE THESE INSTRUCTIONS FOR FUTURE REFERENCE.** Save the original box and packaging. Use this packaging to ship the equipment if repairs are needed.

SAFETY PRECAUTIONS

To ensure safe operation, read the following statements and understand their meaning. This manual contains safety precautions which are explained below. Please read carefully.

WARNING

Warning is used to indicate the presence of a hazard that *can* cause *severe* personal injury, death, or substantial property damage if the warning is ignored.

CAUTION

Caution is used to indicate the presence of a hazard that *will* or *can* cause *minor* personal injury or property damage if the caution is ignored.

NOTE

Note is used to notify people of installation, operation, or maintenance information that is important but not hazard-related.

For Your Safety!

These precautions should be followed at all times. Failure to follow these precautions could result in injury to yourself and others.

To reduce risk of injury or damage to the unit:

1. Do not operate unattended.
2. Unit must be only used in a flat, level position.
3. Change oil regularly or as necessary. Old or dirty oil has a lower flash point than clean oil.
4. Fill to correct level with oil. Do not over fill.
5. Do not overfill basket. Do not fill basket more than half full.
6. Hot oil is flammable - keep open flames away from hot oil and oil vapors.
7. Unplug unit, turn off and let it cool before cleaning or moving.
8. Do not spray controls or outside of unit with liquids or cleaning agents.
9. Do not operate unit in public areas and/or around children.
10. The unit and oil may be hot even though the Pilot Light is not on.
11. Do not operate if unit has been damaged or is malfunctioning in any way.
12. Do not tamper with the Safe Operation Switch or Over Temperature Protection Switch.
13. Do not spray controls or outside of unit with liquids or cleaning agents.
14. Do not clean the unit with steel wool.
15. Dispose of oil in an environmentally responsible manner.

FUNCTION AND PURPOSE

This unit is intended to be used for deep frying foods in commercial foodservice operations only. It is not intended for household, industrial or laboratory use.

Before using this equipment it must be cleaned and **dried thoroughly**. Clean all surfaces before use. Failure to clean surfaces before using the unit could cause food contamination.

This fryer is a medium duty appliance capable of a wide variety of frying applications. The temperature is thermostatically controlled between 120°F (49°C) and 400°F (204°C). The thermostat is also the ON/OFF switch. An indicator lamp adjacent to the thermostat dial indicates when the elements are heating.

UNPACKING THE EQUIPMENT

Dispose of all packaging, materials in an environmentally responsible manner.

1. Remove all packing material and tape, as well as any protective plastic from the unit.
2. Clean any glue residue left over from the plastic or tape.
3. Place the unit in the desired position and height.
4. Plug unit into a properly grounded electrical supply matching the nameplate rating. Damage to the unit can occur if incorrect power is supplied to unit.

INSTALLATION SAFETY PRECAUTIONS

	WARNING
	Fire Hazard. Correct installation precautions, procedures and regulations must be followed. Operation and safety training is necessary for all users of this equipment.
The equipment must be installed by qualified personal only. Correct installation precautions, procedures and regulations must be followed in order to reduce the risk of fire. Hood and fire suppression systems must be maintained per manufacture's guidelines. Only personnel qualified and trained are to use this equipment.	

1. The fryer must not be installed under combustible materials and the minimum clearance from combustible construction must be 6" (15 cm) from the sides and back of the fryer. The area surrounding the fryer should be kept free and clear of combustible materials.
2. All deep fryers must be installed with at least 16" (40.6 cm) space between the fryer and surface flames from adjacent cooking equipment.
3. Equipment must installed by a qualified personal in accordance with federal, state and local codes.
4. The fryer should be installed under a hood in accordance with the latest edition of the Standard for Ventilation Control and Fire Protection of Commercial Cooking Operations, NFPA 96.
5. Never direct the automatic fire extinguishers so they can blow the oil out of the container.
6. Locate the fryer in a place where it cannot be pushed off counter.
7. Keep the area at the front of the fryer clear for unobstructed access during operation.
8. Keep unit and power cord away from open flames, electric burners or excessive heat.
9. Use only grounded electrical outlets matching the nameplate rated voltage.
10. Do not use an extension cord with this equipment.
11. Do not spray controls or outside of unit with liquids or cleaning agents.



FEATURES AND CONTROLS



Figure 1. Features and Controls

- (A)** THERMOSTAT CONTROL dial. Used to set or adjust the temperature of the well. The numbers on the dial correspond with the oil temperature. The “0” position is off.
- (B)** OVER TEMPERATURE RESET SWITCH and COVER. Remove cover to access the reset switch. If the oil reaches a temperature of 430°F (221°C) this switch cuts power to the unit.
- (C)** HIGH OIL LEVEL. This is the maximum level mark for the well. Do not fill with oil above this mark because it may cause oil to overflow the well after the basket of food has been added.
- (D)** LOW OIL LEVEL. This is the minimum level mark for the well. Do not operate with oil below this level as the oil may overheat and start a fire.
- (E)** LIFTING HANDLES. Used to lift the well in and out of the unit for oil disposal and cleaning.
- (F)** WELL. Holds the oil and is where the cooking takes place. A heating element is suspended in this component.
- (G)** HEATING ELEMENT. This is what heats the oil or lard.
- (H)** PILOT LIGHT. This light indicating that the element is heating. Once the temperature has been reached the light will go out. Unit will continue to maintain heat and temperature with light cycling on and off. This is not an “ON/OFF” light.

OPERATION

Follow these same instructions for each well of a two well unit. Each well operates independently and may be operated a different temperatures.

1. Remove basket(s) from fryer.
2. Fill or add oil/solid shorting to the well (F). Always maintain oil level between High Oil Level (C) and Low Oil Level (D) as indicated on the side of the well. See Figure 1. DO NOT overfill.

	WARNING
	<p>Burn Hazard. Do not touch hot liquid or heating surfaces while unit is heating or operating.</p>
<p>Hot liquids and food can burn skin. Allow the hot liquid to cool before handling. Do not drop or spill water into hot oil as it will spray or splatter the hot oil out of the tank.</p>	

	WARNING
	<p>Fire Hazard. Overheated oil or oil vapors can ignite causing a fire. Monitor oil temperature, quality and level. Use and maintain oil vapor removal system.</p>
<p>Heat oil carefully. If oil smokes, reduce heat. Do not leave unit unattended. If fire occurs, turn unit off, cover until cool. Do not put water on hot or flaming oil. Do not operate with oil below low oil mark. Dirty oil has a lower flash point. Replace oil on a regular basis. Maintain correct oil level. Use an oil vapor removal system (hood) to reduce oil and grease buildup on wall or ceiling surfaces.</p>	

3. Adjust the thermostat control (A) to the desired temperature; the pilot light (H) indicates when the elements are energized. If lard or solid type oil is used the unit must be pulsed in 1 to 2 minute on and off cycles at low-med temperature until liquid covers the heating coils. This will reduce smoking and risk of fire.
4. Allow the unit to preheat and the oil to come up to cooking temperature, approximately 15 minutes. The pilot light (H) will cycle when the oil has reached the set temperature.
5. Load each basket; NEVER more that half way full.
6. Carefully lower the basket into the cooking oil.
7. When removing the basket from the oil, allow the excess oil to drain back into the well before transferring to holding area.

OIL TIPS

1. Use high quality oil.
2. Cook at temperatures that are recommended by food manufacture.
3. Change oil as needed or food quality requires.
4. Skim oil often and filter daily.
5. Cover oil overnight.

CLEANING

To maintain the appearance and increase the service life, clean your unit daily.

	WARNING
	Burn Hazard. Do not touch hot liquid or heating surfaces while unit is heating or operating.
Hot liquids and food can burn skin. Allow the hot liquid to cool before handling. Do not drop or spill water into hot oil as it will spray or splatter the hot oil out of the tank.	

	WARNING
	Fire Hazard. Overheated oil or oil vapors can ignite causing a fire. Monitor oil temperature, quality and level. Use and maintain oil vapor removal system.
Heat oil carefully. If oil smokes, reduce heat. Do not leave unit unattended. If fire occurs, turn unit off, cover until cool. Do not put water on hot or flaming oil. Do not operate with oil below low oil mark. Dirty oil has a lower flash point. Replace oil on a regular basis. Maintain correct oil level. Use an oil vapor removal system (hood) to reduce oil and grease buildup on wall or ceiling surfaces.	

NOTE:

Do not clean the unit with steel wool.

1. Allow the unit and oil to cool completely before cleaning.

	WARNING
	Electrical Shock Hazard. Keep water and other liquids from entering the inside of the unit. Liquid inside the unit could cause an electrical shock.
Do not spray water or cleaning products. Liquid could contact the electrical components and cause a short circuit or an electrical shock. Do not use unit if power cord is damaged or has been modified	

2. Unplug the unit.
3. Do not immerse the cord, plug or controls in water or any other liquid.
4. Rotate the fryer head to the up position (A). See Figure 2.
5. Carefully remove the well(s) (C) from the unit and filter or discard used oil.
6. Using a damp cloth or sponge dipped in soapy water to clean the unit and well(s); rinse thoroughly.
 Or, you may also fill the well(s) (C, Figure 1) with water and dish washing liquid. Lower fryer head to the down position (B) and boil it for a few minutes; rinse thoroughly. It's important that the unit doesn't run dry as it will cause the element to burn out.
7. Dry thoroughly after cleaning.

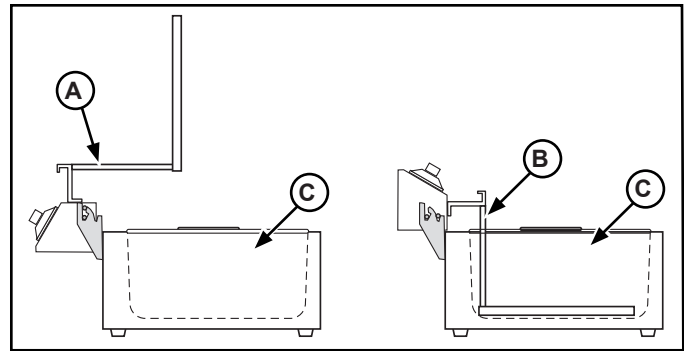

Figure 2. Hinge Positions.

TROUBLESHOOTING

TEMPERATURE SAFETY RESET SWITCH

This unit is equipped with a switch that cuts off power if the oil temperature reaches 430°F (221°C). This switch has a manual reset. The reset switch and cover (B) is located on the front panel of the unit. See Figure 1. Determine what caused the safety switch to activate and correct it. Possible causes include; dirty oil, low oil level and element not properly submerged in oil.

To reset the temperature safety switch:

1. Wait until the oil has cooled to 300°F (149°C) or below.
2. Remove the switch cover (A) by unscrewing counterclockwise. See Figure 3.

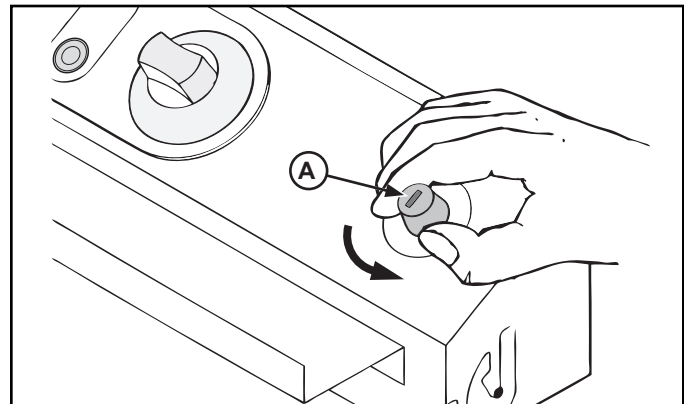

Figure 3. Switch Cover Removal.

3. Use a pen or similar narrow tool (A) and press the reset button (B) down. The button should stay in the down or in the set position. See Figure 4.

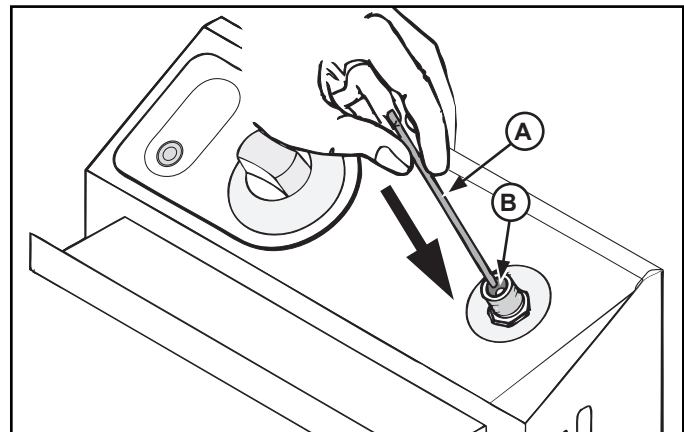

Figure 4. Resetting Switch.

4. Replace the switch cover and secure by screwing clockwise. See Figure 5.

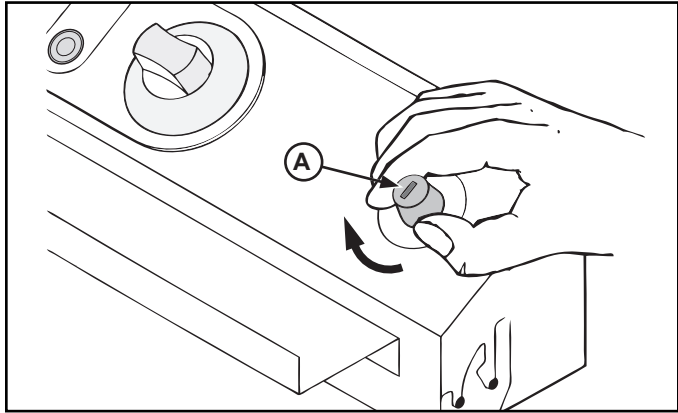

Figure 5. Switch Cover Installation

If unable to reset the temperature safety switch or the switch continues to trip, contact Vollrath Technical Service.

SAFE OPERATION SWITCH

This unit is equipped with a safe operation switch. The switch allows power to the heating element when it is in the correct position. See Figure 6. Safe operation switch:

1. When the heating element (B) is in the correct or down position the safe operation switch (A) is pushed in and the heating element will be supplied with power.
2. When the heating element is in the up position (C) or removed from the unit, switch (D) goes to the "OFF" position and cuts power to the heating element.

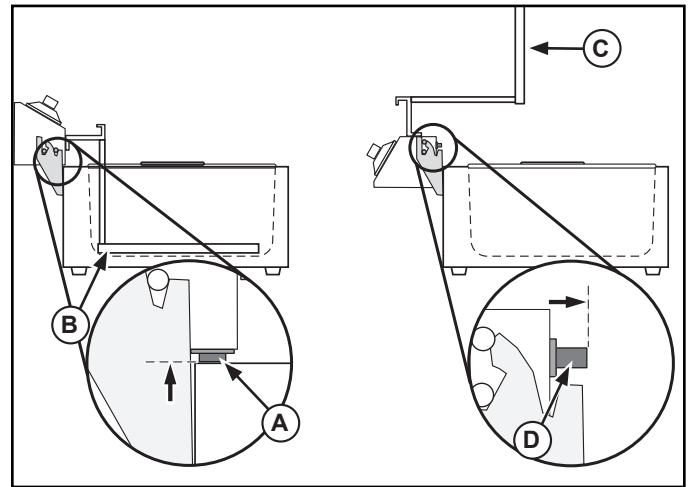

Figure 6. Safe Operation Switch.

TROUBLESHOOTING CHART

Problem	It might be caused by	Course of Action
Pilot Light does not come on when the temperature control is turned up.	Unit is not plugged in.	Plug unit in.
	Safe Operation Switch in "OFF" position.	Check Safe Operation Switch is in "ON" position.
	Temperature safety switch is tripped.	Reset temperature safety switch.
	Pilot Light malfunction.	Replace Pilot Light.
Oil gets too hot.	Oil level low.	Turn unit off, allow to cool and add oil to proper level.
	Thermostat Control malfunction.	Replace Thermostat Control.
Oil does not get hot enough.	Thermostat Control malfunction.	Replace Thermostat Control.
Oil heats slowly.	Low or incorrect voltage to unit.	Verify that voltage rating in unit matches the source voltage. If not have qualified electrical personnel install proper source voltage.
Oil boils over top when frying.	Too much oil in well.	Reduce the amount of oil in well
	Too much food in basket.	Reduce the amount of food in basket.
	Too much water in food.	Dry food product or remove ice crystals from food prior to frying.

SERVICE AND REPAIR

There are no user serviceable parts within this appliance. To avoid serious injury or damage, never attempt to repair the unit or replace a damaged power cord yourself. Do not send units directly to the Vollrath Company. Please contact the qualified professional repair service listed below.

VOLLRATH Technical Service • 1-800-628-0832

SPARE PARTS LIST - COUNTERTOP FRYER, MODELS ~ 40705, 40706, 40707, 40708

Callout	Part Number	Description
1	FFEB100	Fryer Head Assembly, 120V (includes Ref. No. 2, 3, 4, 5, 6, 7, 9, 10, 11, 12, 13, 14, 15, 16, 17)
1	FFEB200	Fryer Head Assembly, 220V (includes Ref. No. 2, 3, 4, 5, 6, 7, 9, 10, 11, 12, 13, 14, 15, 16, 17)
2	XAA0011	Pilot Light, 120V, Amber
2	XAA0002	Pilot Light, 220V, Red
3	N/A	Control Panel Insert
4	XAA0009	Control Panel Facia
5	N/A	Element Box
6	XFFA0004	Thermostat Control Knob
7	XFFA0013	Temperature Safety Switch Cover
8	N/A	Temperature Safety Switch Label
9	XFFA0008	Thermostat
10	XFFA0009	Temperature Safety Switch Sensor
11	XFA0011	Micro Switch
12	XFFA0012	Safe Operation Switch
13	N/A	Back Plate
14	XCOA1013	Power Cord Restraint
15	XAA0005	Power Cord, 120V, NEMA 5-15P Plug
15	XAA0006	Power Cord, 220V, NEMA 6-15P Plug
16	N/A	Element Cover
17	XFFA0002	Heating Element, 120V ~ 1800 Watt
17	XFFA0003	Heating Element, 220V ~ 2500 Watt
18	FFB1250	Basket, Small
19	FFB2250	Basket, Large*
20	XFEIN001	Fryer Insert
21	N/A	Hinge, Right Side
22	N/A	Hinge, Left Side
23	XTSA0004	Foot, Rubber
24	N/A	Fryer Body, Single
25	N/A	Fryer Body, Double
26	40713	Night Cover, Large Basket*
26	40714	Night Cover, Small Basket*

* *Optional Equipment*



EXPLODED VIEW - COUNTERTOP FRYER, MODELS ~ 40705, 40706, 40707, 40708

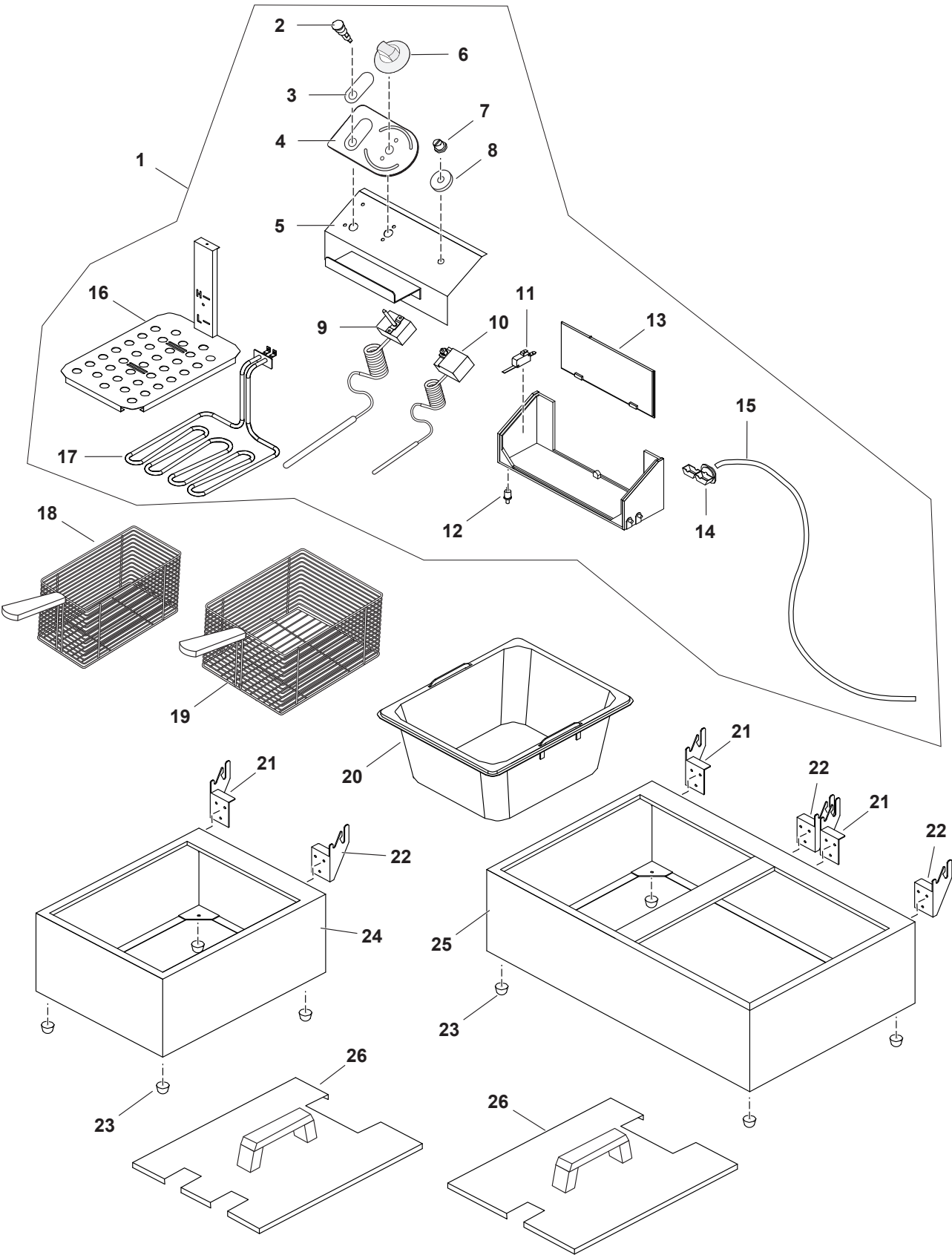

ENGLISH

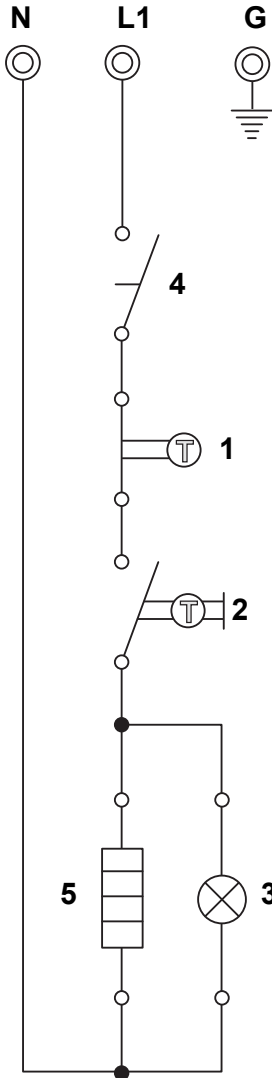
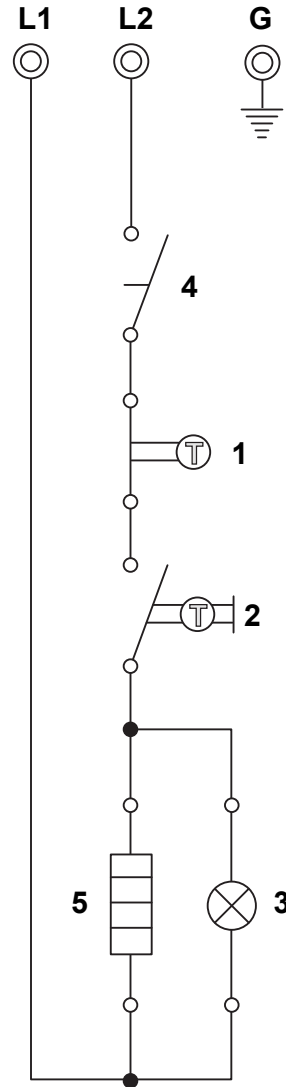
WIRING DIAGRAM - MODELS 40705 AND 40707
WIRING DIAGRAM - MODELS 40706 AND 40708
120V ~ 1800Watt

208V-240V 2500Watt

Callout	Part Number	Description
1	XFFA0009	Safety Thermostat
2	XFFA0008	Temperature Control Thermostat
3	XAA0011	Pilot Light, 120V, Amber
4	XFA0011	Micro Switch
5	XFFA0002	Heating Element, 120V ~ 1800 Watt

Callout	Part Number	Description
1	XFFA0009	Safety Thermostat
2	XFFA0008	Temperature Control Thermostat
3	XAA0002	Pilot Light, 220V, Red
4	XFA0011	Micro Switch
5	XFFA0003	Heating Element, 220V ~ 2500 Watt



WARRANTY STATEMENT FOR THE VOLLRATH Co. L.L.C.

The Vollrath Company LLC warrants the products it manufactures and distributes against defects in materials and workmanship for a period of one year, except as specifically provided below. The warranty runs 12 months from the date of original installation. (End user receipt)

1. Refrigeration compressors – The warranty period is 5 years.
2. Replacement parts – The warranty period is 90 days.
3. Fry pans and coated cookware – The warranty period is 90 days
4. EverTite™ Riveting System – The warranty covers loose rivets only, forever.
5. Cayenne® Heat Strips – The warranty period is 1 year plus an additional 1 year period on heating element parts only.
6. Ultra and Professional Induction Ranges – The warranty period is 2 years.
7. Mirage and Commercial Induction ranges - The warranty period is 1 year.
8. ServeWell® Induction Workstations – The warranty period is one year on the workstation table and 2 years on induction hobs.
9. Slicers – The warranty period is 10 years on gears and 5 years on belts.
10. Mixers – The warranty period is 2 years.
11. Extended warranties are available at the time of sale.
12. Boxer Mixers – 1 Year exchange Warranty.
13. Vollrath – Redco products – The warranty period is 2 years.
14. Optio / Arkadia product lines – The warranty period is 90 days.
15. All non-stick products (i.e. fry pans and surfaces) are 90 days for the non stick surfaces.

All products in the Jacob's Pride® collection, including the following, have a lifetime warranty:

- NSF Certified One-Piece Dishes
- NSF Certified Spoodle® Utensils
- NSF Certified Heavy-Duty Spoons with Ergonomic Handle
- NSF Certified Heavy-Duty Basting Spoons
- Heavy duty Turners with Ergonomic handle
- One-Piece Tongs*
- Heavy-Duty One-Piece Ladles*
- Nylon Handle Whips
- One-Piece Skimmers
- Tribute®, Intrigue®, and Classic Select® Cookware*

*Jacob's Pride® warranty does not cover Kool-Touch®, non stick coatings and silicone handles.

Items sold having no warranty:

- Meat Grinder Knives
- Light Bulbs in Convection Ovens and Hot Food Merchandiser
- Oven Door Seals
- Oven Door Glass
- Hot Food Merchandisers / Display Case Glass
- Calibration and set up of gas equipment
- Slicer / Dicer blades (table top food prep) – Redco and Vollrath

THIS WARRANTY IS IN LIEU OF ANY OTHER WARRANTIES, EXPRESS OR IMPLIED, INCLUDING ANY IMPLIED WARRANTY OF MERCHANTABILITY OR FITNESS FOR A PARTICULAR PURPOSE

As The Vollrath Company LLC's only responsibility and the purchaser's only remedy, for any breach of warranty, The Vollrath Company LLC will repair or, at its option, replace the defective product or part without charge, except as otherwise provided below:

- For refrigeration compressors and the second year of the warranty on Cayenne® Heat Strips and mixers, The Vollrath Company LLC will provide the repaired or replacement part only; and the buyer will be responsible for all labor charges incurred in performing the repair or replacement.
- To obtain warranty service, the buyer will be responsible to return to The Vollrath Company LLC any product (other than gas equipment that is permanently installed) weighing less than 110 lbs. or located outside of a 50-mile radius of a certified technician designated by The Vollrath Company LLC to perform warranty repairs. If a Vollrath Technician cannot be contacted check the website for service contact points. (Please refer to the Product Catalogue for weights and sizes of product)
- No remedy will be available for products that have been damaged by accident, carelessness, improper installation, lack of proper setup or supervision when required, neglect, improper use, installation or operation contrary to installation and operating instructions or other causes not arising out of defects in materials or workmanship. At the buyer's request, The Vollrath Company LLC will repair and or replace such products at a reasonable cost.
- No remedy will be available for slicers where blade has not been sharpened (Refer to owner's manual for sharpening instructions)
- No remedy will be available for mixers damaged by changing gears while unit is running or overloading, in either case as determined by a Vollrath Certified Technician
- Warranty work must be authorized in advance by The Vollrath Company LLC. See the operating and safety instructions for each product for detailed warranty claim procedures.
- No remedy will be available for product returned and found to be acceptable to the product specification.
- No remedy will be available under any warranty not registered as required below.

LIMITATION OF LIABILITY:

THE VOLLRATH COMPANY LLC SHALL HAVE NO LIABILITY FOR INCIDENTAL OR CONSEQUENTIAL DAMAGES OF ANY KIND, WHETHER BASED UPON NEGLIGENCE OR OTHER TORT, BREACH OF WARRANTY, OR ANY OTHER THEORY.



WARRANTY PROCEDURE

On all warranty calls, the following process and information is required:

- All warranty claims will start with a call to Vollrath Technical Service support line.(800-628-0832).
- A technical support professional will work to diagnose the issues, and provide the details for the service solution.
- Name and phone number of person calling
- Business name, street address, city, state and zip
- Model and serial number
- Date of purchase and proof of purchase (Receipt)
- Name of dealer where unit was purchased

NOTE: Vollrath will not accept products sent without the proper procedure being followed.

Important:

TO MAKE A CLAIM FOR ANY REMEDY UNDER THIS WARRANTY, YOU MUST REGISTER YOUR WARRANTY.

REGISTER TODAY

ONLINE: Register your warranty on-line now at www.Vollrathco.com

NO WEB ACCESS: If you do not have access to the web, kindly register by completing the warranty registration form and faxing it to The Vollrath Co. LLC office in the country of purchase.

WARRANTY REGISTRATION			
BUSINESS NAME			
KEY CONTACT NAME		EMAIL	
STREET ADDRESS			
CITY	STATE	ZIP CODE	
COUNTRY	PHONE	FAX	
MODEL		ITEM NUMBER	
SERIAL NUMBER	<input type="text"/>	-	<input type="text"/>
OPERATION TYPE			
<input type="checkbox"/> Limited Service Restaurant	<input type="checkbox"/> Full Service Restaurant	<input type="checkbox"/> Bars and Taverns	<input type="checkbox"/> Supermarket
<input type="checkbox"/> Convenience Store	<input type="checkbox"/> Recreation	<input type="checkbox"/> Hotel/Lodging	<input type="checkbox"/> Airlines
<input type="checkbox"/> Business/Industry	<input type="checkbox"/> Primary/Secondary School	<input type="checkbox"/> Colleges/University	<input type="checkbox"/> Hospitals
<input type="checkbox"/> Long-Term Care	<input type="checkbox"/> Senior Living	<input type="checkbox"/> Military	<input type="checkbox"/> Corrections
REASON FOR SELECTING OUR PRODUCT			
<input type="checkbox"/> Appearance	<input type="checkbox"/> Full Service Restaurant	<input type="checkbox"/> Availability	<input type="checkbox"/> Sellers Recommendation
<input type="checkbox"/> Ease of Operation	<input type="checkbox"/> Versatility of Use	<input type="checkbox"/> Price	<input type="checkbox"/> Brand
WOULD YOU LIKE TO RECEIVE OUR FULL-LINE CATALOG AND REMAIN ON OUR MAILING LIST?			<input type="checkbox"/> Yes <input type="checkbox"/> No

ENGLISH





www.vollrathco.com

The Vollrath Company, L.L.C.
1236 North 18th Street
Sheboygan, WI 53081-3201
U.S.A.

Main Tel: 800.628.0830
Fax: 800.752.5620

Technical Services: 800.628.0832
Service Fax: 920.459.5462

Canada Service: 800.695.8560

© 2010 The Vollrath Company, L.L.C.

