

Operator's Manual

FOODSERVICE INDUCTION RANGES



Model	Description	Voltage	HZ	kW	Plug
69504	Countertop – Single	208 - 240	50/60	3.0 - 3.5	6-20P
69505	Drop-in – Single	208 - 240	50/60	3.0 - 3.5	6-20P
69507	Countertop – Dual, Front-to-Back	208 - 240	50/60	3.0 - 3.5	6-50P
69508	Drop-in – Dual, Front-to-Back	208 - 240	50/60	3.0 - 3.5	6-50P
69520	Countertop – Single	208 - 240	50/60	2.5 - 2.9	6-20P
69521	Drop-in – Single	208 - 240	50/60	2.5 - 2.9	6-20P
69523	Countertop – Dual, Side By Side	208 - 240	50/60	2.5 - 2.9	6-30P
69522	Countertop – Dual, Front-to-Back	208 - 240	50/60	2.5 - 2.9	6-30P
69524	Drop-in – Dual, Front-to-Back	208 - 240	50/60	2.5 - 2.9	6-30P
69543	Countertop – Single	208 - 240	50/60	2.2 - 2.6	
69547	Countertop – Dual, Front-to-Back	208 - 240	50/60	3.3 - 3.8	
6954301	Countertop – Single	208 - 240	50/60	2.2 - 2.6	6-20P
6954302	Countertop – Single	208 - 240	50/60	2.2 - 2.6	Schuko
6954303	Countertop – Single	208 - 240	50/60	2.2 - 2.6	UK
6954701	Countertop – Dual, Front-to-Back	208 - 240	50/60	3.3 - 3.8	6-20P
6954702	Countertop – Dual, Front-to-Back	208 - 240	50/60	3.3 - 3.8	Schuko
6954703	Countertop – Dual, Front-to-Back	208 - 240	50/60	3.3 - 3.8	UK

Thank you for purchasing this Vollrath Induction Range. Before operating the unit, read and familiarize yourself with the following operating and safety instructions. SAVE THE ORIGINAL BOX AND PACKAGING. Use this packaging to ship the unit if repairs are needed. SAVE THESE INSTRUCTIONS FOR FUTURE REFERENCE.

SAFETY PRECAUTIONS

To ensure safe operation, read the following statements and understand their meaning. This manual contains safety precautions which are explained below. Please read carefully.

WARNING

Warning is used to indicate the presence of a hazard that *can* cause severe personal injury, death, or substantial property damage if the warning is ignored.

CAUTION

Caution is used to indicate the presence of a hazard that *will* or *can* cause *minor* personal injury or property damage if the caution is ignored.

NOTE

Note is used to notify people of installation, operation, or maintenance information that is important but not hazard-related.

For Your Safety!

These precautions should be followed at all times. Failure to follow these precautions could result in injury to yourself and others.

To reduce risk of injury or damage to the unit:

- Plug only into grounded electrical outlets matching the nameplate rated voltage. Each induction unit should have a separate circuit.
- Do not use an extension cord with this equipment. Do not plug this equipment into a power strip or multi-outlet power cord.
- As a precaution, persons using a pacemaker should stand back 12" (30 cm) from an operating unit. Studies have shown that the induction element will not disrupt a pacemaker.
- Keep all credit cards, driver licenses and other items with a magnetic strip away from an operating unit. The unit's magnetic field will damage the information on these strips.
- The heating surface is made of a strong, non-porous material. However, should it crack or break, stop using and immediately unplug the unit.
- Do not leave an empty pan on an operating unit.
- Unit should only be used in a flat, level position.
- Unplug unit and let it cool before cleaning or moving.
- Do not touch the cooking surface. It remains hot after the unit is turned off.
- Do not spray controls or outside of unit with liquids or cleaning agents.
- Unplug when not in use.
- Keep unit and power cord away from open flames, electric burners or excessive heat.
- Do not heat sealed cans or containers as they may explode.
- Do not operate unattended. Closely supervise units operating in public areas and/or around children.

- Do not operate if unit has been damaged or is malfunctioning in any way.
- Do not place any objects inside the air intake or exhaust panels.
- Do not place weight on the control knob.

FUNCTION AND PURPOSE

This unit is intended to be used with induction-ready cookware (see below) with a flat, ferrous base measuring 4-1/2" (11.4 cm) to 10-1/4" (26 cm) wide. This unit is intended for use in commercial foodservice operations only. It is not intended for household, industrial or laboratory use.

INDUCTION READY COOKWARE

- Ferrous stainless steel
- Iron
- Cast iron

UNSUITABLE COOKWARE

- Cookware with a base less than 4-1/2" (11.4 cm)
- Pottery, glass, aluminum, bronze or copper cookware
- Cookware with any type of footed base

This unit is to be used on a flat, level surface. The unit is not designed to be enclosed or built into any area.

NOTE:

There must be a minimum of 4" (10 cm) between the induction range and any surrounding surface to allow sufficient airflow around the unit. Blocking the airflow could overheat the unit

INSTALLATION

COUTERTOP

1. Place the induction range/warmer on a flat stable surface.

NOTE:

This unit is not designed to be inclosed or built into any area.

There must be a minimum of 4" (10 cm) of space between the rear of the induction warmer and any surrounding surface.

There must be 3/4" (2 cm) between the bottom of the induction warmer and any surrounding surface.

Sufficient airflow must be allowed around the unit. Blocking the airflow could cause the unit to overheat.

2. Plug the power cord into a grounded electrical outlet with the matching nameplate rated voltage.

NOTE:

Using a voltage other than the nameplate rated voltage will cause damage to the unit. Incorrect voltage, modification to the power cord or electrical components can damage unit and will void the warranty. Induction units are to use a separate dedicated circuit.



DROP-IN

1. Choose a flat, level countertop for the mounting surface.

NOTE:

There must be a minimum of 3" (7.6 cm) of space between the rear of the induction warmer and any surrounding surface.

There must be 1" (2.5 cm) between the bottom of the induction warmer and any surrounding surface.

Sufficient airflow must be allowed around the unit. Blocking the airflow could cause the unit to overheat.

2. Measure the area for the cutout, including the countersink area. The unit is designed to be countersunk. The depth of the surface around the cutout must be reduced to allow for the countersink. See the illustration below.

NOTE:

Exposed wood or particle board edges must be sealed with an appropriate waterproofing material. Seal the edge between the glass and the countertop with silicone or similar material. Failure to do so may result in damage to the countertop.

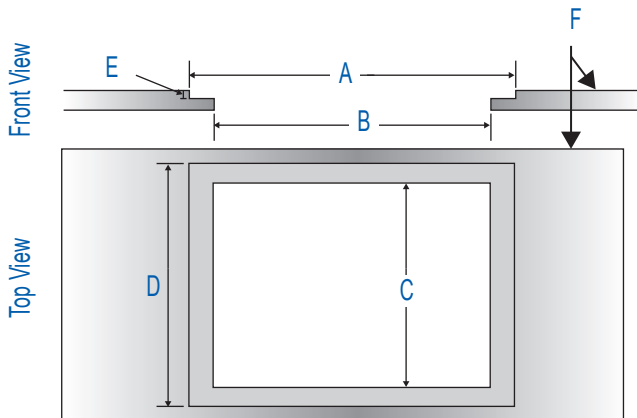

<i>Cutout Dimensions - Models 69505 and 69521</i>	
Dimension	Size
A	N/A
B	16¼" (41.3 cm)
C	15¼" (38.7 cm)
D	N/A
E	N/A
F	Countertop

<i>Cutout Dimensions Models 69508 and 69524</i>	
Dimension	Size
A	N/A
B	15 ¹³ / ₁₆ " (40.1 cm)
C	26 ¹ / ₃ " (66.8 cm)
D	N/A
E	N/A
F	Countertop

<i>Control Cutout Dimensions (Models 69508 and 69524 require two)</i>	
Dimension	Size
A	N/A
B	7 ³ / ₈ " (18.7 cm)
C	3 ¹³ / ₁₆ " (9.7 cm)
D	N/A
E	N/A
F	Countertop

3. Seal the joint between the induction warmer and countertop.
4. Plug the power cord into a grounded electrical outlet with the matching nameplate rated voltage.

NOTE:

Using a voltage other than the nameplate rated voltage will cause damage to the unit. Incorrect voltage, modification to the power cord or electrical components can damage unit and will void the warranty. Induction units are to use a separate dedicated circuit.

ENGLISH

OPERATION

	WARNING
	<p>Electrical Shock Hazard. Keep water and other liquids from entering the inside of the unit. Liquid inside the unit could cause an electrical shock.</p>

Electrical Shock Hazard!

If liquid spills or boils over onto the unit, immediately unplug the unit and remove cookware. Wipe up any liquid with a padded cloth.

- Place the induction-ready cookware containing food in the center position of a hob.

NOTE:

Do not pre-heat empty cookware. Because of the speed and efficiency of the induction range, cookware can very quickly overheat and be damaged.

NOTE:

Do not drop cooking utensils or other objects onto the cooking surface. The strong, non-porous surface will break. The warranty does not cover this type of abuse.

- Press the ON/OFF button. The power level display will light. The power level LED will light. When an induction ready cookware pan is placed on the heating surface, the display will remain on, indicating the unit is heating.

	WARNING
	<p>Burn Hazard. Do not touch cookware, heating surface, food, or liquid while heating.</p>

Burn Hazard!

Hot food and liquids can burn skin. Induction heating surfaces heat very rapidly. Use caution when adding pre-heated oil, liquid or other food already in the cookware.

The unit is equipped with an “over-heating protection” feature. If the temperature of the cooking surface becomes too hot, the unit will turn off. The display will flash “F2” to indicate the unit is in “over-heating protection” mode. After the unit has cooled, turn the cooking surface on and if “F2” is not displayed, then cooking can resume.

The display window should remain constant during operation. If the display is flashing, see the Troubleshooting section in this manual.

Removing cookware from the cooking surface for more than five minutes will cause the unit to automatically turn off. Removing cookware for less than five minutes will not interrupt operation of the unit.

The unit will start in Power Control Mode when it is turned on first time.

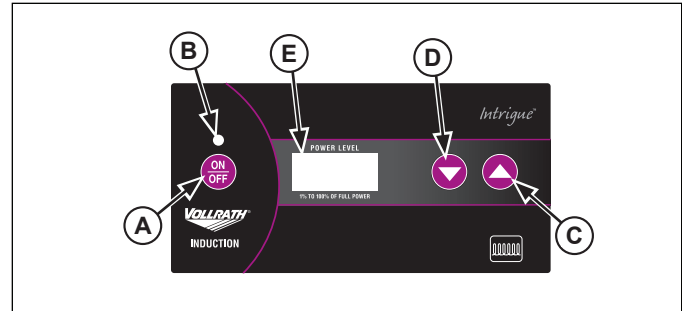

Control Panel Example

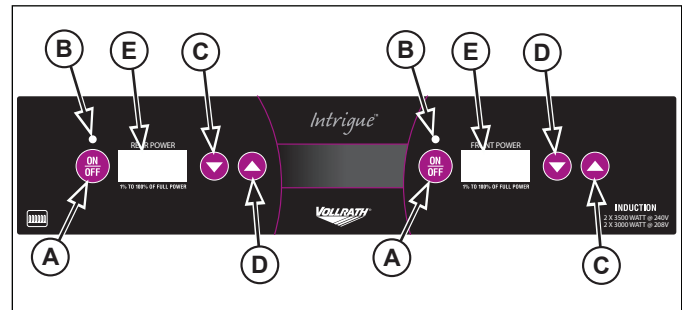

Control Panel Example

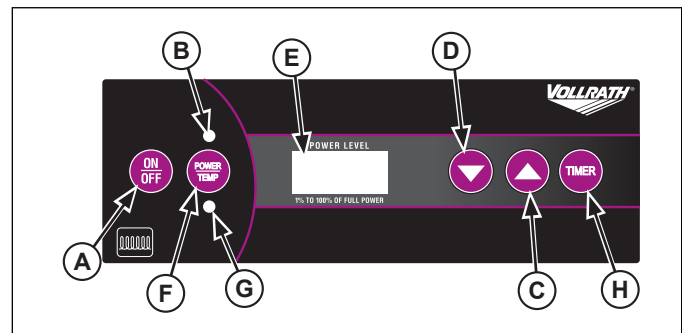

Control Panel Example

- A** ON/OFF button. Press to turn unit on. An LED above the control will illuminate when switched on.
- B** POWER on LED light. Illuminates when the power is switched on.
- C** UP button. Used to increase the power level or time depending upon the mode selected and model.
- D** DOWN button. Used to decrease the power level or time depending upon the mode selected and model.
- E** DISPLAY panel. Displays the power level or time depending upon the mode selected and model.
- F** POWER/TEMP button. Used to change the mode and display panel from power to temperature.



- Ⓒ TEMPERATURE LED light. Illuminates when the unit is in the temperature mode. This light is constant or blinks depending on the model.
- Ⓗ TIMER button. Used to switch on and start the timer function.

Adjusting the Power and Temperature

1. Press the ON/OFF button to turn on the unit. The Power LED will illuminate. When induction-ready cookware is placed on the range, the display will remain “steady on” with a value. This indicates the unit is heating. Models with two heating surfaces will have separate ON/OFF buttons for each heating surface.
2. Press the POWER/TEMP button (some models) to choose a cooking power level (1 – 100) or an approximate temperature (100° – 400° F) or press again for (60° – 210° C).
3. Press the UP button or DOWN button to increase or decrease the power level or temperature.

Activating the Timer

1. Press the TIMER button. The display will show “1” with a flashing dot in the lower right corner.
2. Press the up or down arrow to set the timer from 1 to 180 minutes.
3. When the timer cycle is complete, the unit will turn off.
4. To cancel the timer, press the ON/OFF button. The timer will turn off and the unit will return to the power or temperature mode.



CLEANING

To maintain the appearance and increase the service life, clean your induction range daily.

	 WARNING
	Burn Hazard. Do not touch cookware, heating surface, food, or liquid while heating.

Burn Hazard!

Hot food and liquids can burn skin. Induction heating surfaces heat very rapidly. Allow the heating surface to cool before handling.

	 WARNING
	Electrical Shock Hazard. Keep water and other liquids from entering the inside of the unit. Liquid inside the unit could cause an electrical shock.

Electrical Shock Hazard!

Do not spray water of cleaning products. Liquid could contact the electrical components and cause a short circuit or an electrical shock.

1. Unplug the unit and let it completely cool.
2. Wipe the unit exterior with a clean damp cloth.
3. Do not use abrasive materials, scratching cleansers or scouring pad to clean the unit. These can damage the finish.
4. Thoroughly wipe off any mild soap or chemical cleaners. Residue could corrode the surface of the unit.

ENGLISH

TROUBLESHOOTING

Problem	It might be caused by	Course of Action
The unit turned off after 1, 5, or 10 minute(s) depending upon the unit.	There is not a pot/pan on the induction range or the pot/pan is not induction-ready cookware. The induction range turned off. This is normal.	Make sure the pot/pan is induction ready. See page 1 of this manual.
The unit is on, but not heating.	The cookware may be too small or may not be induction-ready.	Make sure the pot/pan is induction ready. See page 1 of this manual.
The digital display lights are flashing.	The overheat-protection feature may have activated.	Remove cookware. Let cooking surface cool.
The unit suddenly stopped working.	The unit may be too close to an external heat source or the air intake may be restricted.	Relocate the unit away from any external heat source. Clear any obstructions to the air intake.

SERVICE AND REPAIR

There are no user serviceable parts within this appliance. To avoid serious injury or damage, never attempt to repair the induction range or replace a damaged power cord yourself. Do not send units directly to the Vollrath Company. Please contact the qualified professional repair service listed below.

VOLLRATH Induction Repair Service • 1-800-825-6036 (USA) or www.vollrathco.com

When contacting the Authorized Professional Service Center, please be ready with the model number, serial number, and proof of purchase showing the date the unit was purchased.

WARRANTY STATEMENT FOR THE VOLLRATH CO. L.L.C.

The Vollrath Company LLC warrants the products it manufactures and distributes against defects in materials and workmanship for a period of one year, except as specifically provided below. The warranty runs 12 months from the date of original installation. (End user receipt)

1. Refrigeration compressors – The warranty period is 5 years.
2. Replacement parts – The warranty period is 90 days.
3. Fry pans and coated cookware – The warranty period is 90 days
4. EverTite™ Riveting System – The warranty covers loose rivets only, forever.
5. Cayenne® Heat Strips – The warranty period is 1 year plus an additional 1 year period on heating element parts only.
6. Ultra and Professional Induction Ranges – The warranty period is 2 years.
7. Mirage and Commercial Induction ranges - The warranty period is 1 year.
8. ServeWell® Induction Workstations – The warranty period is one year on the workstation table and 2 years on induction hobs.
9. Slicers – The warranty period is 10 years on gears and 5 years on belts.
10. Mixers – The warranty period is 2 years.
11. Extended warranties are available at the time of sale.
12. Vollrath – Redco products – The warranty period is 2 years.
13. Optio / Arkadia product lines – The warranty period is 90 days.
14. All non-stick products (i.e. fry pans and surfaces) are 90 days for the non stick surfaces.

All products in the Jacob's Pride® collection, including the following, have a lifetime warranty:

- NSF Certified One-Piece Dishers
- NSF Certified Spoodle® Utensils
- NSF Certified Heavy-Duty Spoons with Ergonomic Handle
- NSF Certified Heavy-Duty Basting Spoons
- Heavy duty Turners with Ergonomic handle
- One-Piece Tongs*
- Heavy-Duty One-Piece Ladles*
- Nylon Handle Whips
- One-Piece Skimmers
- Tribute®, Intrigue®, and Classic Select® Cookware*

*Jacob's Pride® warranty does not cover Kool-Touch®, non stick coatings and silicone handles.

Items sold having no warranty:

- Meat Grinder Knives
- Light Bulbs in Convection Ovens and Hot Food Merchandiser
- Oven Door Seals
- Oven Door Glass
- Hot Food Merchandisers / Display Case Glass
- Calibration and set up of gas equipment
- Slicer / Dicer blades (table top food prep) – Redco and Vollrath

THIS WARRANTY IS IN LIEU OF ANY OTHER WARRANTIES, EXPRESS OR IMPLIED, INCLUDING ANY IMPLIED WARRANTY OF MERCHANTABILITY OR FITNESS FOR A PARTICULAR PURPOSE

As The Vollrath Company LLC's only responsibility and the purchaser's only remedy, for any breach of warranty, The Vollrath Company LLC will repair or, at its option, replace the defective product or part without charge, except as otherwise provided below:

- For refrigeration compressors and the second year of the warranty on Cayenne® Heat Strips and mixers, The Vollrath Company LLC will provide the repaired or replacement part only; and the buyer will be responsible for all labor charges incurred in performing the repair or replacement.
- To obtain warranty service, the buyer will be responsible to return to The Vollrath Company LLC any product (other than gas equipment that is permanently installed) weighing less than 110 lbs. or located outside of a 50-mile radius of a certified technician designated by The Vollrath Company LLC to perform warranty repairs. If a Vollrath Technician cannot be contacted check the website for service contact points. (Please refer to the Product Catalogue for weights and sizes of product)
- No remedy will be available for products that have been damaged by accident, carelessness, improper installation, lack of proper setup or supervision when required, neglect, improper use, installation or operation contrary to installation and operating instructions or other causes not arising out of defects in materials or workmanship. At the buyer's request, The Vollrath Company LLC will repair and or replace such products at a reasonable cost.
- No remedy will be available for slicers where blade has not been sharpened (Refer to owner's manual for sharpening instructions)
- No remedy will be available for mixers damaged by changing gears while unit is running or overloading, in either case as determined by a Vollrath Certified Technician
- Warranty work must be authorized in advance by The Vollrath Company LLC. See the operating and safety instructions for each product for detailed warranty claim procedures.
- No remedy will be available for product returned and found to be acceptable to the product specification.
- No remedy will be available under any warranty not registered as required below.

LIMITATION OF LIABILITY:

THE VOLLRATH COMPANY LLC SHALL HAVE NO LIABILITY FOR INCIDENTAL OR CONSEQUENTIAL DAMAGES OF ANY KIND, WHETHER BASED UPON NEGLIGENCE OR OTHER TORT, BREACH OF WARRANTY, OR ANY OTHER THEORY.

INDUCTION RANGE WARRANTY INFORMATION

The Vollrath Company will warranty the induction ranges covered in this manual for a period of two (2) years in accordance with the policy stated above. Any damages from improper use, abuse, modification or damage resulting from improper packaging during return shipment for warranty repair will not be covered under warranty.



WARRANTY PROCEDURE

On all warranty calls, the following process and information is required:

- All warranty claims will start with a call to Vollrath Technical Service support line (800-628-0832).
- A technical support professional will work to diagnose the issues, and provide the details for the service solution.
- Name and phone number of person calling
- Business name, street address, city, state and zip
- Model and serial number
- Date of purchase and proof of purchase (Receipt)
- Name of dealer where unit was purchased

NOTE: Vollrath will not accept products sent without the proper procedure being followed.

Important:

TO MAKE A CLAIM FOR ANY REMEDY UNDER THIS WARRANTY, YOU MUST REGISTER YOUR WARRANTY.

REGISTER TODAY

ONLINE: Register your warranty on-line now at www.Vollrathco.com

NO WEB ACCESS: If you do not have access to the web, kindly register by completing the warranty registration form and faxing it to The Vollrath Co. LLC office in the country of purchase.

WARRANTY REGISTRATION			
BUSINESS NAME			
KEY CONTACT NAME		EMAIL	
STREET ADDRESS			
CITY		STATE	ZIP CODE
COUNTRY	PHONE	FAX	
MODEL		ITEM NUMBER	
SERIAL NUMBER	<input type="text"/>	-	<input type="text"/>
OPERATION TYPE			
<input type="checkbox"/> Limited Service Restaurant	<input type="checkbox"/> Full Service Restaurant	<input type="checkbox"/> Bars and Taverns	<input type="checkbox"/> Supermarket
<input type="checkbox"/> Convenience Store	<input type="checkbox"/> Recreation	<input type="checkbox"/> Hotel/Lodging	<input type="checkbox"/> Airlines
<input type="checkbox"/> Business/Industry	<input type="checkbox"/> Primary/Secondary School	<input type="checkbox"/> Colleges/University	<input type="checkbox"/> Hospitals
<input type="checkbox"/> Long-Term Care	<input type="checkbox"/> Senior Living	<input type="checkbox"/> Military	<input type="checkbox"/> Corrections
REASON FOR SELECTING OUR PRODUCT			
<input type="checkbox"/> Appearance	<input type="checkbox"/> Full Service Restaurant	<input type="checkbox"/> Availability	<input type="checkbox"/> Sellers Recommendation
<input type="checkbox"/> Ease of Operation	<input type="checkbox"/> Versatility of Use	<input type="checkbox"/> Price	<input type="checkbox"/> Brand
WOULD YOU LIKE TO RECEIVE OUR FULL-LINE CATALOG AND REMAIN ON OUR MAILING LIST?			<input type="checkbox"/> Yes <input type="checkbox"/> No

ENGLISH



www.vollrathco.com

The Vollrath Company, L.L.C.
1236 North 18th Street
Sheboygan, WI 53081-3201
U.S.A.

Main Tel: 800.628.0830
Fax: 800.752.5620

Technical Services: 800.628.0832
Service Fax: 920.459.5462

Canada Service: 800.695.8560

© 2011 The Vollrath Company, L.L.C.

